

## □ COMMUNITY FOCAL POINTS

The Village Center and Activity Core are to be a central focus of activity, and will have a highly visible community presence.

**Village Center** - The Village Center is planned as a unique and diverse mixed-use hub of activities. The Village Center is envisioned as the heart of the WRSP, a destination where residents will live, meet, shop, eat, recreate, obtain services and socialize. The anticipated mix of uses may include retail, restaurant, service, office, public, ~~theater~~, church, school, park and high/medium density housing. Emphasis is placed on the pedestrian, rather than the auto, and on consistency with the City's General Plan Pedestrian District level of service policy. The Village Center is modeled towards a traditional urban town center rather than a suburban shopping center.

**Activity Core** - The City's Regional Sports Park is planned east of the Pleasant Grove Wastewater Treatment Plant, encompassing a portion of the required 1000-foot non-residential buffer. Immediately to the east of the Regional Sports Park is a planned high school site, and further to the east and close by, Fiddymont Park. The central proximity of these facilities, along with the inclusion of multiple vehicular, pedestrian and bicycle connection points, are intended to facilitate accessibility between facilities and to nearby residents. Combined, the park, school and adjacent open space areas generate a distinct central core of active and passive recreation, education, joint use opportunities, and community activity. The Activity Core will draw users from both within and outside the WRSP..

## □ RESIDENTIAL NEIGHBORHOODS

Low density single-family residential is the predominant land use within the WRSP, and a defining characteristic of the community. The Residential Neighborhoods surround the Activity Core with approximately 40% of Plan Area units to the north and east of the Activity Core, and 60% to the south and west.

Neighborhoods include a mix of low, medium and high density residential uses consistent with the character of the City. Schools and parks are located in neighborhoods within walking distance of most residences. Medium and high-density residential is incorporated, proximate to services and recreational areas and to provide a separation between single-family residential and more intense land uses.



*Residential Neighborhoods*

A variety of housing styles similar to that found elsewhere in the City are planned, including affordable housing and designated age restricted neighborhoods.

#### ☐ **SERVICE AND NEIGHBORHOOD NODES**

Outside of the Village Center and Activity Core, service uses and community facilities are dispersed throughout the WRSP in a hierarchy of Service and Neighborhood Nodes. The WRSP is designed to create interconnectivity between the various nodes and the surrounding neighborhoods. These linkages include pedestrian and bicycle pathways along adjacent open space, paseos and roadway corridors. In most cases, high-density residential uses have been sited adjacent to or in close proximity to the service nodes.



*Service Nodes*

**Service Nodes** – Retail, office and other commercial/service uses are provided in Service Nodes within the WRSP. The Service Nodes consist primarily of commercial centers located along major circulation corridors. In most cases, high-density residential use has been sited adjacent to or in close proximity to the service nodes. One Business Professional parcel has been included that may accommodate small office complexes intended to provide services to Plan Area residents.

## 3.2 PLANNING PRINCIPLES

### □ GENERAL:

1. Create a comprehensively planned residential based community balanced by a mix of employment, commercial, business professional, service, recreation, open space, and public uses;
2. Provide a logical and orderly extension of the City of Roseville that is compatible with surrounding land uses, that complements the pattern and intensity of existing development in the City and provides new benefits to the City;
3. Satisfy City policies, regulations and expectations as defined in the General Plan, West Roseville Guiding Principles, City-County MOU, Zoning Ordinance, Improvement and Construction Standards and other applicable plans, documents and programs adopted by the City;
4. Aid the City in meeting its recognized obligation to accommodate a percentage of future population growth in the region by increasing the residential holding capacity by ~~10,495~~ 8,460 residential units in an area identified in the City's feasibility analyses as feasible for such development;
5. Ensure compatibility with the adjacent Pleasant Grove Wastewater Treatment Plant and other potential future intensive public uses, including the proposed Roseville Energy Park, through inclusion of appropriate uses within the 1000 foot non-residential buffer area around the plant; and
6. Offer a low-density age-restricted community as a component to the WRSP to compliment the age-restricted community in the Del Webb Specific Plan and to respond to the market preferences and needs of senior adults as they relate to type, size, cost of housing, and recreational and social amenities.

### □ USES AND FORM:

7. Shape a physical form and character of development that is functional and creates a sense of place that will:
  - a. Establish an identifiable western edge of the City of Roseville through inclusion of contiguous permanent open space areas;
  - b. Enhance Roseville's supply of and reputation for quality housing that provides a diversity of housing opportunities available to residents from a wide range of economic levels and all stages of life;
  - c. Organize neighborhoods to be identifiable, walkable and to incorporate gathering places, such as parks and schools, for neighborhood activities and interaction;

## 4 LAND USE PLAN & REGULATIONS

### 4.1 OVERVIEW

The West Roseville Specific Plan land use plan includes a blend of residential, service, employment, open space and public uses. The Plan Area will house approximately ~~25,9634~~ ~~25,922~~ residents and ~~4,735~~ ~~5,011~~ employees. WRSP land uses are reflected on Figure 4-1, and are summarized on Table 4-1. A parcel-by-parcel land use, zoning, and unit summary is included on Table 4-2. Given its unique nature, a more detailed discussion of the proposed Village Center is included as Section 10, Village Center Plan.

### 4.2 PERMITTED USES & DEVELOPMENT STANDARDS

Land uses within the West Roseville Specific Plan will be implemented by the application of permitted, conditionally permitted and/or administratively permitted uses designated by the zoning district applied to each parcel. Except as otherwise provided in this Specific Plan, permitted uses, development standards, processing requirements and other regulations are as specified by the City of Roseville Zoning Ordinance (Municipal Code Chapter 19).

In accordance with the Zoning Ordinance, the WRSP has applied the Development Standards (DS) and Special Area (SA) overlay zones to customize development standards and/or permitted uses of general zone districts where needed. A summary of zoning districts and overlay zones applied by the WRSP is included in Table 4-3. Guidance relating to the application of these overlay zones is provided in this section.

The WRSP Design Guidelines (Section 12) include additional detail to be considered in the design, review and approval of individual projects. The WRSP Design Guidelines supplement the Citywide Design Guidelines and other City requirements by identifying considerations unique to the character and development objectives of the Plan Area. Development within the Plan Area is required to comply with the WRSP Design Guidelines, and all applicable City requirements.

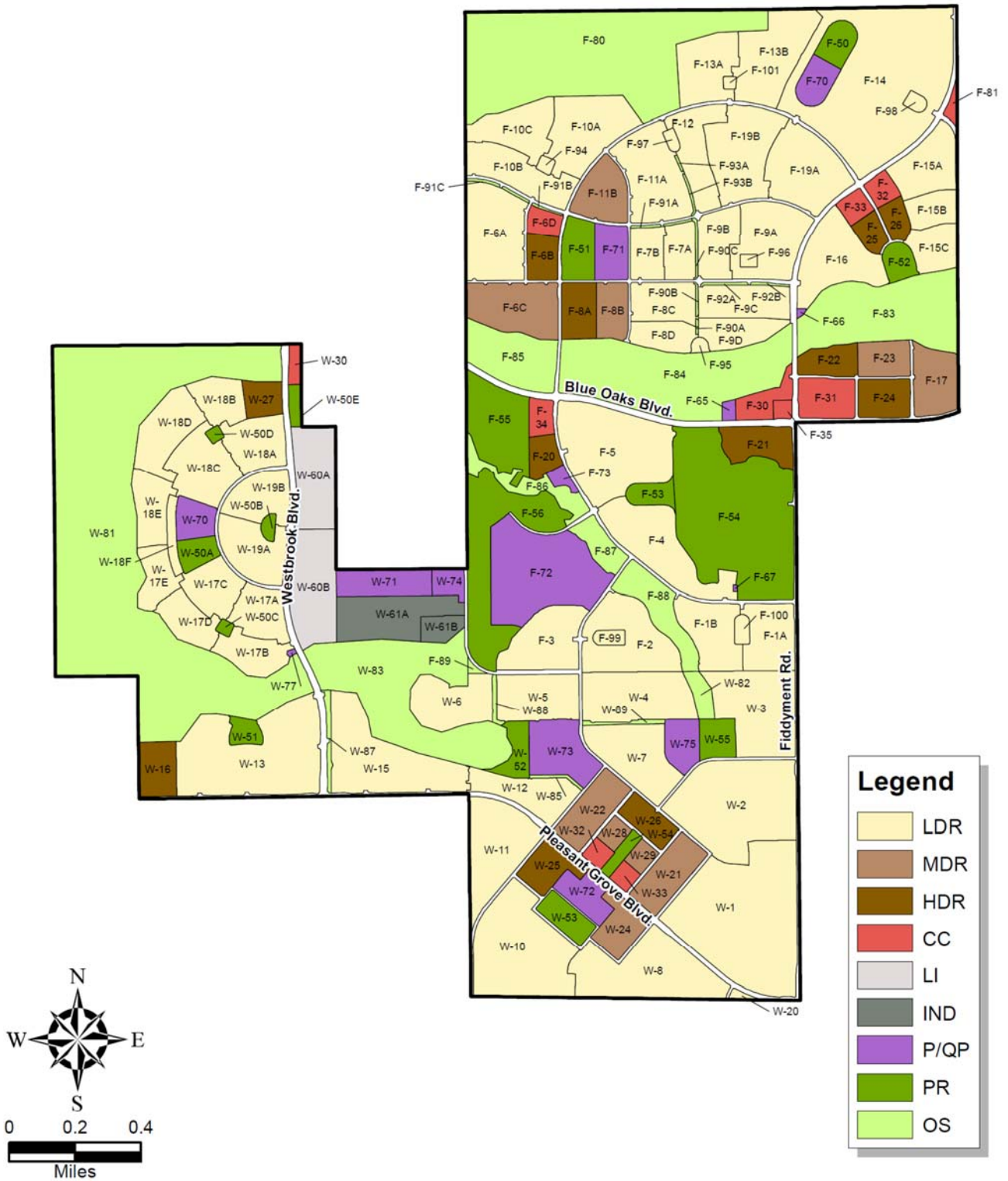
**Table 4-1: Land Use Summary**

General Plan Land Use (Specific Plan Land Use)	Acres	% of Total Acres	Allocated Units	% of Total Units
<b>Residential</b>				
LDR (Residential)	1,337.81	42.29%	5,903	56.33%
LDR (Age Restricted)	146.79	4.64%	704	6.72%
LDR (Pocket Park)	13.43	0.42%	0	0.00%
MDR (Residential)	79.71	2.18%	836	8.01%
MDR (VC-Residential)	<del>53.73</del> <b>46.13</b>	<del>1.70</del> <b>1.46%</b>	<del>454</del> <b>387</b>	<del>4.23</del> <b>3.69%</b>
HDR (Residential)	93.33	3.29%	2,212	21.19%
HDR (VC-Residential)	9.39	0.30%	<del>154</del> <b>165</b>	1.57%
HDR (VC-Residential / Senior)	12.36	0.39%	232	2.21%
<b>Subtotal</b>	<del>1,746.55</del> <b>1,738.66</b>	<del>55.22</del> <b>54.97%</b>	<del>10,495</del> <b>10,439</b>	<del>100.00</del> <b>99.62%</b>
<b>Service and Employment</b>				
CC (Commercial)	48.74	1.54%	0	0.00%
CC (VC-Commercial)	<del>6.41</del> <b>13.81</b>	<del>0.20</del> <b>0.44%</b>	<del>0</del> <b>40</b>	<del>0.00</del> <b>0.38%</b>
LI (Light Industrial)	55.15	1.74%	0	0.00%
IND (Industrial)	32.86	1.04%	0	0.00%
<b>Subtotal</b>	<del>143.16</del> <b>150.61</b>	<del>4.52</del> <b>4.76%</b>	<del>0</del> <b>40</b>	<del>0.00</del> <b>0.38%</b>
<b>Open Space and Public</b>				
OS (Open Space)	690.79	21.84%	0	0.00%
OS (Paseo)	13.93	0.44%	0	0.00%
PR (Park)	67.40	2.13%	0	0.00%
PR (Fiddymment Park)	95.56	3.02%	0	0.00%
PR (Sports Complex)	75.13	2.38%	0	0.00%
PR (VC-Park)	8.98	0.28%	0	0.00%
PR (VC-Village Green)	<del>3.71</del> <b>3.85</b>	0.12%	0	0.00%
P/QP (Elementary School)	37.51	1.19%	0	0.00%
P/QP (Middle School)	20.28	0.64%	0	0.00%
P/QP (High School)	52.85	1.67%	0	0.00%
P/QP (Fire Station)	2.51	0.08%	0	0.00%
P/QP (Well)	0.74	0.04%	0	0.00%
P/QP (Water Tank)	5.35	0.17%	0	0.00%
P/QP (WWTP)	15.00	0.47%	0	0.00%
P/QP (Substation)	1.55	0.05%	0	0.00%
P/QP (VC-Church)	10.83	0.34%	0	0.00%
ROW (Right of Way)	<del>170.76</del> <b>170.82</b>	5.40%	0	0.00%
<b>Subtotal</b>	<del>1,273.36</del> <b>1,273.47</b>	40.26%	0	0.00%
<b>Total</b>	<b>3,162.59</b>	<b>100.00%</b>	<b>10,495</b> <b>479</b>	<b>100.00%</b>

Last update \_\_\_\_\_, ~~2017~~ **September 23, 2015**

Figure 4-1: Land Use Plan

REVISED FIGURE



Parcel	General Plan Land Use (Specific Plan Land Use)	Zoning	Acres	Allocated Units	Density
F-66	P/QP (Well)	P/QP	0.36		
F-67	P/QP (Well)	P/QP	0.17		
F-70	P/QP (Elementary School)	P/QP	8.51		
F-71	P/QP (Elementary School)	P/QP	10.60		
F-72	P/QP (High School)	P/QP	52.85		
F-73	P/QP (Fire Station)	P/QP	2.51		
F-80	OS (Open Space)	OS	131.94		
F-81	CC ( <del>Commercial</del> Commercial)	CC	1.97		
F-83	OS (Open Space)	OS	59.17		
F-84	OS (Open Space)	OS	81.20		
F-85	OS (Open Space)	OS	26.91		
F-86	OS (Open Space)	OS	12.94		
F-87	OS (Open Space)	OS	8.98		
F-88	OS (Open Space)	OS	18.31		
F-89	OS (Open Space)	OS	0.74		
F-90A	OS (Paseo)	OS	0.28		
F-90B	OS (Paseo)	OS	0.57		
F-90C	OS (Paseo)	OS	0.96		
F-91A	OS (Paseo)	OS	1.02		
F-91B	OS (Paseo)	OS	0.35		
F-91C	OS (Paseo)	OS	0.94		
F-92A	OS (Paseo)	OS	0.76		
F-92B	OS (Paseo)	OS	0.64		
F-93	OS (Paseo)	OS	0.94		
F-94	LDR (Pocket Park)	RS/DS	1.26	0	0.0
F-95	LDR (Pocket Park)	RS/DS	1.27	0	0.0
F-96	LDR (Pocket Park)	RS/DS	1.30	0	0.0
F-97	LDR (Pocket Park)	RS/DS	1.31	0	0.0
F-98	LDR (Pocket Park)	RS/DS	2.00	0	0.0
F-99	LDR (Pocket Park)	R1/DS	2.77	0	0.0
F-100	LDR (Pocket Park)	R1/DS	2.52	0	0.0
F-101	LDR (Pocket Park)	RS/DS	0.96	0	0.0
<b>Fiddymnt Total:</b>			<b>1,587.96</b>	<b>5,868</b>	
W-1	LDR (Age Restricted)	RS/DS	87.08	404	4.6
W-2	LDR (Age Restricted)	RS/DS	59.71	300	5.0
W-3	LDR (Residential)	RS/DS	37.88	198	5.2
W-4	LDR (Residential)	R1/DS	31.82	147	4.6
W-5	LDR (Residential)	R1/DS	22.62	88	3.9
W-6	LDR (Residential)	R1/DS	22.75	77	3.4
W-7	LDR (Residential)	R1/DS	27.92	111	4.0
W-8	LDR (Residential)	R1/DS	43.76	168	3.8
W-10	LDR (Residential)	R1/DS	52.43	245	4.7
W-11	LDR (Residential)	R1/DS	32.31	130	4.0
W-12	LDR (Residential)	RS/DS	18.87	78	4.1
W-13	LDR (Residential)	RS/DS	64.51	310	4.8
W-15	LDR (Residential)	RS/DS	45.14	224	5.0
W-16	HDR (Residential)	R3	12.15	250	20.6
W-17A	LDR (Residential)	RS/DS	14.83	66	4.5
W-17B	LDR (Residential)	RS/DS	14.06	56	4.0
W-17C	LDR (Residential)	RS/DS	14.93	69	4.6
W-17D	LDR (Residential)	RS/DS	13.05	53	4.1
W-17E	LDR (Residential)	RS/DS	11.42	41	3.6
W-18A	LDR (Residential)	RS/DS	17.60	86	4.9
W-18B	LDR (Residential)	RS/DS	12.62	57	4.5
W-18C	LDR (Residential)	RS/DS	23.01	102	4.4
W-18D	LDR (Residential)	RS/DS	21.50	92	4.3
W-18E	LDR (Residential)	RS/DS	14.35	52	3.6

Land Use Plan & Regulations

Parcel	General Plan Land Use (Specific Plan Land Use)	Zoning	Acres	Allocated Units	Density
W-18F	LDR (Residential)	RS/DS	4.39	19	4.3
W-19A	LDR (Residential)	RS/DS	20.33	109	5.4
W-19B	LDR (Residential)	RS/DS	16.61	85	5.1
W-20	LDR (Residential)	R1/DS	1.09	0	0.0
W-27	HDR (Residential)	R3	7.92	170	21.5
W-30	CC (Commercial)	CC	2.99		
W-50A	PR (Park)	P/R	6.52		
W-50B	PR (Park)	P/R	1.92		
W-50C	PR (Park)	P/R	1.21		
W-50D	PR (Park)	P/R	1.23		
W-50E	PR (Park)	P/R	3.11		
W-51	PR (Park)	P/R	4.69		
W-52	PR (Park)	P/R	7.99		
W-55	PR (Park)	P/R	8.39		
W-60A	LI (Light Industrial)	M1/SA	25.18		
W-60B	LI (Light Industrial)	M1/SA	29.98		
W-61A	IND (Industrial)	M2/SA	26.86		
W-61B	IND (Industrial)	M2/SA	6.00		
W-70	P/QP (Elementary School)	P/QP	8.50		
W-71	P/QP (WWTP)	P/QP	14.99		
W-73	P/QP (Middle School)	P/QP	20.28		
W-74	P/QP (Water Tank)	P/QP	5.36		
W-75	P/QP (Elementary School)	P/QP	9.91		
W-77	P/QP (Well)	P/QP	0.30		
W-81	OS (Open Space)	OS	267.47		
W-82	OS (Open Space)	OS	5.18		
W-83	OS (Open Space)	OS	78.20		
W-85	OS (Paseo)	OS	1.09		
W-87	OS (Paseo)	OS	2.82		
W-88	OS (Paseo)	OS	1.47		
W-89	OS (Paseo)	OS	1.80		
<b>Westpark Total:</b>			<b>1307.37</b>	<b>3,786</b>	
W-21	MDR (VC-Residential)	R3/DS	16.87	138	8.2
W-22	MDR (VC-Residential)	R3/DS	16.61	138	8.3
W-24	MDR (VC-Residential)	R3/DS	12.65	122	9.6
W-25	HDR (VC-Residential / Senior)	R3/DS	12.36	232	18.8
W-26	HDR (VC-Residential)	R3/DS	9.39	154	16.4
<u>W-28</u>	<u>MDR (VC-Residential)</u>	<u>RS/DS</u>	<u>3.80</u>	<u>28</u>	<u>7.4</u>
<u>W-29</u>	<u>MDR (VC-Residential)</u>	<u>RS/DS</u>	<u>3.80</u>	<u>28</u>	<u>7.4</u>
W-32	CC (VC-Commercial)	CC/SA-WR	<del>3.31</del> 6.94	<del>20</del>	<del>2.9</del>
W-33	CC (VC-Commercial)	CC/SA-WR	<del>3.10</del> 6.90	<del>20</del>	<del>2.9</del>
W-53	PR (VC-Park)	P/R	8.98		
W-54	PR (VC-Village Green)	P/R	<del>3.71</del> 3.85		
W-72	P/QP (VC-Church)	P/QP/SA-WR	10.83		
<b>Westpark-VC Total</b>			<b>105.41</b> <del>35</del>	<b>840</b> <del>24</del>	
ROW (Right of Way)			<del>161.85</del> 190.25		
<b>Total:</b>			<b>3,162.59</b>	<b>10,495</b> <del>478</del>	

Notes:

Last Updated: September 10, 2015, W-24 Tentative Map

- A verification study conducted in December of 2006 resulted in minor adjustments to the acreage and number of dwelling units.
- The 156 unit allocation on Parcel F-20 includes 36 units transferred from the City's Reserve Unit Pool, as a Residential Density Bonus for affordable housing, approved by CUP-000049 on December 13, 2007.

**Table 4-3: Summary of WRSP Applied Zoning Districts**

Land Use	Applied Zoning Districts	Permitted Uses	Development Standards
<b>Residential Uses</b>			
LDR – Low Density Residential MDR – Medium Density Residential HDR – High Density Residential	R1/DS RS/DS RS/DS & R3/DS R3 & R3/DS	Per Zoning Ordinance Per Zoning Ordinance Per Zoning Ordinance	Modified by WRSP <sup>1</sup> Modified by WRSP <sup>1</sup> Per Zoning Ordinance
<b>Service and Employment Uses</b>			
VC – Village Center CC – Community Commercial LI – Light Industrial IND – General Industrial	See Section 10 CC M1/SA-WR M2/SA-WR	Modified by WRSP <sup>2</sup> Per Zoning Ordinance Modified by WRSP <sup>3</sup> Modified by WRSP <sup>3</sup>	Modified by WRSP <sup>2</sup> Per Zoning Ordinance Per Zoning Ordinance Per Zoning Ordinance
<b>Open Space and Public Uses</b>			
OS – Open Space P/R – Parks & Recreation P/QP – Public/Quasi-Public	OS P/R P/QP	Per Zoning Ordinance Per Zoning Ordinance Per Zoning Ordinance	Per Zoning Ordinance Per Zoning Ordinance Per Zoning Ordinance

Notes:

1. Section 4.2.
2. Village Center Plan (Section 10).
3. Section 4.2, Table 4-6.

**□ SERVICE AND EMPLOYMENT USES**

Service and employment uses in the West Roseville Specific Plan consist of commercial, office, general industrial and light industrial. Included is the Village Center, envisioned as the primary focal point of the community. The Specific Plan emphasizes compatibility and interconnectivity between uses. The WRSP Design Guidelines promote the creation of projects that are desirable, functional, secure, create a strong street presence, and incorporate elements (pathways, access connections, plazas, lighting elements, shading, etc.) that promote pedestrian activity.



Village Center (VC)	
<b>Density Range:</b>	
<b>Typical FAR:</b>	<b>See Village Center Plan, Section 10</b>
<b>Applied Zoning District:</b>	
<b>Description:</b>	<p>The Village Center is planned to accommodate a broad mix and configuration of uses that form the commercial, service, social and activity focus for the WRSP. <del>It is modeled after a traditional urban small town center rather than a suburban shopping complex.</del></p> <p>The Village Center will have a visible presence in the community and create a destination where residents will come to meet, shop, eat, recreate and obtain services. It is the gathering spot of the community: a district where preferences are given to the pedestrian and not the auto, and where interaction and socialization are primary goals and a catalyst for formal and informal activities.</p> <p>The Village Center will accommodate a variety of service, commercial and housing uses. Given the unique nature of the Village Center, and the importance it plays in the overall form of the WRSP, detailed provisions have been established to guide its development. These include unique land use, zoning, improvement and development standards, design guidelines and project processing provisions. Section 10, Village Center Plan, provides a detailed discussion and the requirements associated with this use.</p>
<b>Permitted Uses:</b>	See Village Center Plan, Section 10
<b>Development Standards:</b>	See Village Center Plan, Section 10

- b. Units may only be transferred from an HDR parcel with a density of 18 units per acre or greater to another HDR parcel with a density of 18 units per acre or greater (Parcels F-6B, F-8A, F-20, F-21, F-22, F-23, F-24, F-25, F-26, W-25, W-~~1628~~, W-~~2729~~). In no case may such transfer result in the density of either parcel falling below 18 units per acre. These parcels may receive unit transfers from parcels with densities below 18 units per acre.

Minor density adjustments, if consistent with the above criteria, are contemplated by and within the intent of this Specific Plan and the WRSP EIR and will not require an amendment to the Specific Plan or the City General Plan.

To request a minor density adjustment, the owner or owners of both the transfer and receiving parcels shall submit an Administrative Permit to the Planning Director identifying the impacted parcels, designating the number of units being transferred and providing other documentation as required by the Planning Director to determine compliance with the above unit transfer criteria. Applicant shall also provide a revised Specific Plan Table 4-2 "Land Use, Zoning and Units by Parcel" reflecting the adjusted unit counts and densities. The revised table will be the official record tracking unit allocations to each large lot residential parcel.

If the Planning Director determines that the minor density adjustment is not consistent with the above criteria, the minor density adjustment shall be denied or may be referred or appealed to the Planning Commission for resolution. Any determination of consistency may, at the discretion of the Planning Director, be forwarded the Planning Commission for review. Applicant may request density adjustments that do not comply with the above criteria. Such requests shall require an amendment to the Specific Plan.

All unused units must be transferred prior to approval by the City of the last small lot final map or Design Review Permit for any residential large lot parcel. Any units designated by the Specific Plan to a large lot parcel that are not used by a tentative map/Design Review Permit or are not approved for transfer shall revert to the City unit pool and landowners shall have no subsequent claim to such units.

**Table 5-1: Definition of Household Income Categories**

Income Category	Percent of Median Income
Very Low-Income	Less than 50% of Median
Low-Income	51% to 80% of Median
Middle-Income	81% to 100% of Median
Moderate-Income	101% to 120% of Median
Above Moderate-Income	121% + of Median

It is recognized that the various factors that determine affordability continually change, and that project specific affordability standards need to be established and adjusted as development occurs.

### 5.3 AFFORDABLE HOUSING PROGRAM

Consistent with the General Plan affordable housing goal, ten percent (10%) of the units in the WRSP have been designated for middle-, low- and very low-income households. This includes a mix of purchase housing affordable to middle-income households, and rental housing affordable to low- and very low-income households. Approximately ~~eleven~~ percent (11%) of the affordable housing goal will be available to middle-income residents, ~~forty-nine~~ percent (49%) to low-income residents and forty percent (40%) to very low-income residents. The WRSP affordable housing goal is summarized in Table 5-2.

**Table 5-2: Affordable Housing Goal**

<b>Total Dwelling Units</b>	<b><u>10,495,817 du</u></b>	
<b>10% Affordable Housing Goal</b>	<b><u>1,048,883 du</u></b>	
Middle-Income (purchase)	<u>116,833 du</u>	( <u>11%</u> )
Low-Income (rental)	<u>5,104,444 du</u>	( <u>49%</u> )
Very Low-Income (rental)	<u>422,356 du</u>	(40%)

The WRSP affordable housing goal has been allocated to specific MDR and HDR parcels as identified on Table 5-3, with the designated parcels reflected on Figure 5-1. The intent is to distribute affordable units throughout the WRSP area.

### 8.3 SCHOOLS

The WRSP is within the boundaries of the Roseville City School District (grades K-8) and Roseville Joint Union High School District (grades 9 to 12). The Plan Area will generate an estimated ~~2,635~~ ~~2,621~~ elementary school (K-5) students, ~~912~~ ~~906~~ middle school (6-8) students and ~~1,303~~ ~~1,296~~ high school (9-12) students, as shown on Table 8-2.

**Table 8-2: Student Generation**

	LDR/MDR <sup>1</sup>	HDR <sup>2</sup>	Students Generated	School Capacity	Schools Required
<b>Roseville City School District<sup>2</sup></b>					
Grades K-5	0.3329	0.1118	<del>2,635</del> <del>2,621</del>	600	<del>4.39</del> <del>4.34</del>
Grades 6-8	0.1164	0.0352	<del>912</del> <del>906</del>	1,000	0.91
<b>Roseville Joint Union High School District</b>					
Grades 9-12	0.1700	0.0400	<del>1,303</del> <del>1,296</del>	1,800	<del>0.72</del>

1. ~~7,085~~ ~~29~~ LDR/MDR units and ~~2,473~~ ~~2,513~~ HDR units assumed. 936 age-restricted units not included. ~~Includes 40 units assigned to the Village Center Commercial use.~~
2. Source: Roseville City School District Student Generation Report dated February 28, 2013.

Within the WRSP, four elementary school sites, a minimum of eight and up to ten acres each, are planned (Parcels W-70, W-75, F-70, F-71). One elementary school is located in each phase of the project. In addition, a 20.28-acre middle school (Parcel W-73) is planned northeast of the Village Center south of Pheasant Run. All elementary and middle schools are located adjacent to neighborhood park sites to promote joint use opportunities and create a local activity amenity.

A 52.85-acre high school site (Parcel F-72) is located in the central portion of the WRSP, west of Hayden Parkway adjacent to the Regional Sports Park. The high school and sports park are part of the WRSP Activity Core, providing for education, active and passive recreation, joint use opportunities and community activity. The high school is anticipated to serve students generated both within and outside the Plan Area.

School sites within the WRSP are reserved for the school districts. Facility planning and the sequencing of development of these sites is to be determined by the districts. The WRSP is required to fully mitigate school impacts in accordance with the Specific Plan development agreements and funding agreements with the respective school districts.

WRSP School sites are reflected on Figure 8-2.

## 8.4 PARKS AND RECREATION

Approximately thirty percent (30%) of the WRSP is planned for park and open space use. The parks and open space program provides for a range of active and passive recreational opportunities that exceed the City's General Plan requirement of 9 acres of parkland per 1,000 residents. The WRSP includes: active neighborhood, community and regional park sites; and credited open space and paseo areas. Construction of park and recreation facilities as described in this document is dependent upon adequate construction and long-term maintenance funding.

The placement and sizing of parks is reflective of community need, General Plan policy, proximity to users, ability to promote joint use activities, and existence of natural resources such as floodplain, oak woodland and vernal pool preservation. Parks are generally located within neighborhoods creating a local focal point and activity amenity. In addition, when feasible, park sites have been located adjacent to or connected with open space areas. The resulting interconnected open space and park network provides for pedestrian and bicycle access throughout the WRSP with connections outside the Plan Area.

The general location of WRSP parks and open space is included on Figure 8-2. Details relating to dedication, operation, funding, phasing and construction is included in the Specific Plan development agreements.

### CITY OF ROSEVILLE PARK AND RECREATION REQUIREMENTS

The WRSP provides recreation facilities, parkland and open space to comply with the policies and requirements of the City's General Plan Parks and Recreation Element. The General Plan requires the provision of nine (9) acres of parkland per 1,000 residents. The General Plan requirement is comprised of three (3) acres of city-wide park, three (3) acres of neighborhood and community park, and three (3) acres of credited open space.

The ~~10,495,478~~ dwelling units in the WRSP will generate an estimated population of ~~25,964-25,922~~ residents based on an average household size of 2.54 residents for conventional (non age-restricted) development and 1.8 residents for age-restricted development. The City's requirement of nine (9) acres per 1,000 residents requires a total of 233.~~6830~~ credited acres of parkland in the Plan Area. WRSP park dedication requirements are summarized in Table 8-3.

**Table 8-3: Park Dedication Requirements**

	<b>General Plan Standard</b>	<b>Acreage Required</b>
City-wide Park	3 acres per 1,000 residents	77. <del>8976</del> acres
Neighborhood/Community Park	3 acres per 1,000 residents	77. <del>8977</del> acres
Open Space	3 acres per 1,000 residents	77. <del>9077</del> acres
<b>Total Parkland</b>	<b>9 acres per 1,000 residents</b>	<b>233.<del>6830</del> acres</b>

#### CREDITED PARKLAND AND OPEN SPACE

The WRSP designates a total of 955.~~5064~~ acres in park and open space uses. This total includes 250.~~7892~~ acres of active neighborhood and city-wide parkland, and 704.72 acres of open space and paseo. Of the 250.~~7892~~ acres of active parkland, 170.69 acres are designated for city-wide park and 80.~~0723~~ acres for neighborhood parks. Each acre set aside for active park use is credited as a full acre towards meeting the General Plan park dedication requirement.

In addition to meeting the City's standards for active parkland, the WRSP provides additional passive recreation opportunities in the form of open space areas. Partial credit may be granted for open space areas that include non-traditional informal recreational facilities and open space amenities. Each acre set aside for open space and paseo is credited at 0.10 acre (one acre of credit for each 10 acres dedicated) with the exception of the 47.18 acre creek corridor conservation easement in F-54 Park, which is credited 0.20 (one acre for each 5 acres of easement area). In total, the 955.~~5064~~ acres of parks and open space provided in the WRSP are granted a credit of 283.~~5468~~ acres towards meeting the General Plan park dedication requirement. This credit exceeds the dedication requirement for the WRSP by ~~49.86~~ ~~50.38~~ acres. A summary of WRSP park and open space credits is included on Table 8-4.

#### CREDITED PARK DESCRIPTIONS

The following provides a brief overview of the various components that constitute the WRSP credited park and open space program. Park sites within the WRSP have been designed to include facilities required by the Parks Vision 2010 Master Plan. Additional detail relating to those parks within the Village Center is included in Section 10, Village Center Plan.

**Table 8-4: Summary of Park and Open Space Lands and Credits**

Parcel	Type	Acreage	Credit Ratio	Credited Acreage
<b>CITY-WIDE PARKS</b>				
F-54	City-wide Park portion	48.38	1:1	48.38
F-55	City-wide Park	29.80	1:1	29.80
F-56	City-wide Park	45.35	1:1	45.35
<b>Subtotal</b>		<b>123.53</b>		<b>123.53</b>
<b>NEIGHBORHOOD/COMMUNITY PARKS</b>				
F-50	Neighborhood Park	7.79	1:1	7.79
F-51	Neighborhood Park	11.84	1:1	11.84
F-52	Neighborhood Park	6.33	1:1	6.33
F-53	Neighborhood Park	6.31	1:1	6.31
W-50A-E	Neighborhood Parks	13.99	1:1	13.99
W-51	Neighborhood Park	4.74	1:1	4.74
W-52	Neighborhood Park	7.99	1:1	7.99
W-53	Neighborhood Park (VC)	8.98	1:1	8.98
W-54	Neighborhood Park (VC)	<del>3.713-85</del>	1:1	<del>3.713-85</del>
W-55	Neighborhood Park	8.39	1:1	8.39
<b>Subtotal</b>		<b>80.0721</b>		<b>80.0721</b>
<b>OPEN SPACE</b>				
F-54	Open Space portion	47.18	0.2:1	9.44
F-80	Open Space	131.84	0.1:1	13.18
F-83	Open Space	59.17	0.1:1	5.92
F-84	Open Space	81.22	0.1:1	8.12
F-85	Open Space	26.92	0.1:1	2.69
F-86	Open Space	12.94	0.1:1	1.29
F-87	Open Space	8.98	0.1:1	.90
F-88	Open Space	18.31	0.1:1	1.83
F-89	Open Space	0.74	0.1:1	0.07
W-81	Open Space	267.22	0.1:1	26.72
W-82	Open Space	5.18	0.1:1	0.52
W-83	Open Space	78.27	0.1:1	7.83
F-90 A, B, C	Paseo	1.80	0.1:1	0.18
F-91 A, B, C	Paseo	2.49	0.1:1	0.25
F-92 A, B	Paseo	1.44	0.1:1	0.14
F-93	Paseo	0.93	0.1:1	0.09
W-85	Paseo	1.08	0.1:1	0.11
W-87	Paseo	2.93	0.1:1	0.29
W-88	Paseo	1.46	0.1:1	0.15
W-89	Paseo	2.20	0.1:1	0.22
<b>Subtotal</b>		<b>751.90</b>		<b>79.94</b>
<b>TOTAL</b>		<b>955.5064</b>		<b>283.5468</b>

## CITY-WIDE PARKS

The WRSP includes two city-wide parks, ~~Fiddymment F-54 Park~~ and the ~~Regional Sports F-55 & 56 Park~~. These parks, combined with the adjacent high school site, form the WRSP Activity Core as described in Community Form and Planning Principles, Section 3. Strong interconnectivity between these facilities is important to support joint use and community activity. A continuous greenway comprised of park and open space will connect ~~Fiddymment F-54 Park~~, the ~~Regional Sports Park F-55/56 Park~~ and the high school site. The greenway includes a Class I bike path connection from the Regional Sports Park east through open space (Parcel F-86), to Park F-53 and to ~~Fiddymment F-54 Park~~.

~~Fiddymment Park F-54~~ is a 95.56-acre city-wide park (~~Parcel F-54~~) located south of Blue Oaks Boulevard and west of Fiddymment Road. Fiddymment Park may potentially contain a variety of active and passive recreation opportunities at buildout including bike and pedestrian paths, an outdoor bandstand area, activity greens, a disc golf course and a small multi-purpose center. A City groundwater well site will also be included. The park encumbers the highest concentration of oak woodlands within the WRSP, and will be highly visible as an entry to the Plan Area. A 47.18 acre conservation easement is designated to protect the oak woodlands along Kaseberg Creek, leaving 48.38 acres to be developed with more active uses, and different credit ratios are applied by Table 8-4. Figure 8-3 provides a conceptual plan for ~~Fiddymment F-54 Park~~. Included is a listing of WRSP fee improvements and potential future amenities not associated with development of the WRSP.

~~Regional Sports Park F-55 & 56~~ is a 75.15-acre city-wide park (~~Parcels F-55 and F-56~~) located adjacent to the high school site, south of Blue Oaks Boulevard between Phillip Road and Hayden Parkway. Included on the property is the historic Fiddymment Ranch Main Complex (see Resource Management, Section 6.4). The Sports Park is envisioned as a regional facility available for tournaments and local league play. The combined Regional Sports Park and adjacent high school site will include various recreational joint use facilities such as soccer fields, baseball fields, a lighted soccer/football stadium, tennis courts, softball fields, an outdoor swimming pool, basketball courts and a 400 meter track. The combined Regional Sports Park/high school site includes a concession area with restrooms, outdoor seating and parking lots. Figure 8-4 provides a conceptual plan and listing of potential improvements for the Regional Sports Park.

## NEIGHBORHOOD PARKS

The WRSP includes ten (10) neighborhood park sites distributed throughout the Plan Area. These sites range in size from ~~3.71~~ ~~85~~ to 14.96 acres. Neighborhood parks include a variety of facilities to accommodate local recreation needs including soccer and baseball fields, hard courts, playgrounds, tot lots and picnic areas. Five of the neighborhood parks are located adjacent to schools to support joint use activities. The neighborhood parks create nodes of activity within the neighborhoods.

## 10 VILLAGE CENTER PLAN

### 10.1 INTRODUCTION

The Village Center is envisioned as the heart and primary focus of the West Roseville Specific Plan. Encompassing an area of approximately 120.78 acres, the Village Center provides for a true interactive mixed-use neighborhood. Retail, office, community services, public spaces and parks are integrated with a variety of housing types. The mix, density, and interface between these uses create an environment that is pedestrian friendly and where formal and informal activities are key goals.

***Successful execution of the Village Center is dependent upon a clear articulation of, and a long-term commitment to, the base concepts and principles that define its distinctive form.***

The Village Center presents a unique development form in Roseville, one emblematic of an urban mixed-use environment. It introduces concepts, product types, use patterns, interfaces and development standards that require adjustment to the general philosophies and regulations that typically guide suburban development. Successful execution of the Village Center is dependent upon a clear articulation of, and a long-term commitment to, the base concepts and principles that define its distinctive form. While it is critical that policies and regulations be developed that are firm in ensuring implementation of the Village Center's distinguishing components, it is similarly important to provide sufficient flexibility to accommodate the variety of specific product types and design solutions that could contribute towards its realization.

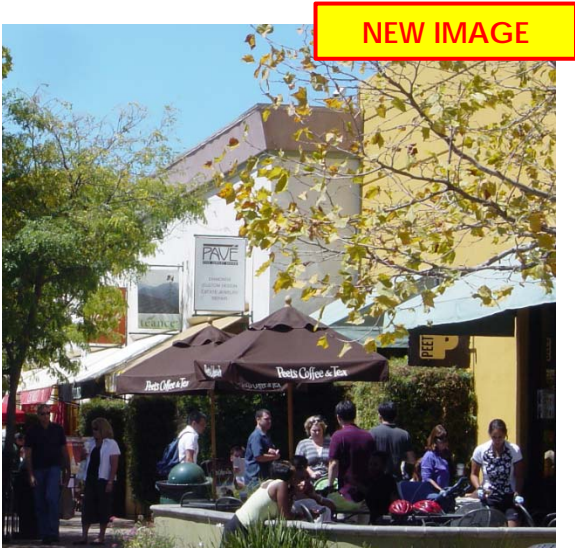


Given the unique nature of the Village Center, and the important role it plays in the WRSP, detailed requirements have been established to guide its development. This section of the Specific Plan provides specific form, planning principles, land use, zoning, development and design standards and processing direction. It supplements other sections of the Specific Plan and includes a more specific level of detail.

## 10.2 VILLAGE CENTER FORM & PLANNING PRINCIPLES

### □ FORM

The Village Center is a core feature and a unique place within the WRSP. It is influenced by the concepts embedded in traditional small town urban villages and smart growth principles such as densities that support transit, a mix of uses, compact development form, a variety of housing opportunities and a pedestrian-friendly environment. The Village Center incorporates a broad mix of uses applied over an urban grid street pattern with a central village green. Included are a blend of higher density residential types, commercial and service uses, and public/quasi-public spaces. The increased density/intensity of development and spatial relationship between uses promote diversity, activity and pedestrian orientation. Numerous design elements, including buildings oriented toward the street and dense tree canopies, are incorporated to further this intent. The Village Center form and density facilitates a variety of transportation options and increases the living choices available in Roseville.

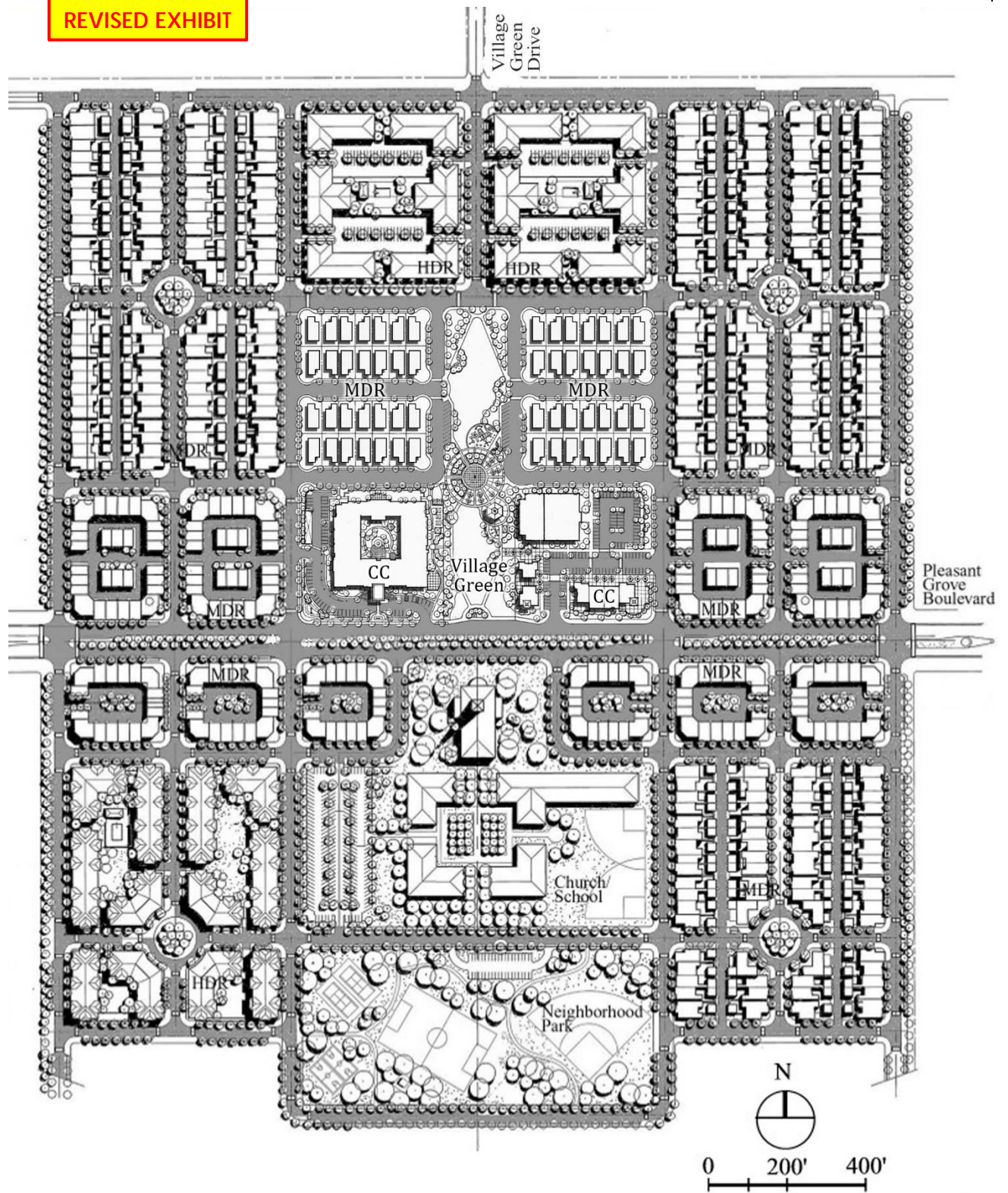


The Village Center is planned to function as the commercial, service, social and activity focus of the WRSP. The Village Center will have a visible presence in the community and create a destination where residents may live, shop, eat, recreate and obtain services. It is the gathering spot and a district where preference is given to the pedestrian. Interaction and socialization are primary goals and a catalyst for formal and informal activities. Uses, activities and amenities are offered that encourage people from throughout the community to come often and stay for extended periods.

The key elements of the Village Center are generally reflected on Figure 10-1, Village Center Illustrative Plan.

Figure 10-1: Village Center Illustrative Plan

REVISED EXHIBIT



PLANNING PRINCIPLES

The Village Center is defined by a combination of its form, uses and design. The following principles describe the major attributes of the use and guide its implementation. The Village Center Planning Principles are highly influenced by and reflective of “Smart Growth” values that promote the creation of walkable mixed-use communities:

*Form:*

- Model the Village Center in the form of a traditional small town village or center;
- Create a clearly identifiable and distinct district that is easy to see, find, get to and comprehend;
- Integrate a mix of uses with multiple destinations within close proximity;
- Increase densities and intensities of uses to support activity and a variety of transportation choices;
- Create a compact development form;
- Provide overlapping interfaces between uses and allow uses to mix;
- Create a pedestrian friendly-walkable community that minimizes barriers, emphasizes the pedestrian over the automobile, and implements the City’s General Plan Pedestrian District policy;
- Incorporate a traditional grid circulation pattern with short blocks, straight streets and intersections at regular intervals;
- Provide for easy and desirable access between uses, and interconnection with adjacent neighborhoods;
- Ensure that streets and sidewalks balance all forms of transportation; and
- Orient all development toward the street (rather than inward or to parking lots) to place activity on the street.

*Uses:*

- Create a wide range of higher density housing choices such as brownstones, townhouses, stacked flats, and apartments;
- Include retail and services uses ~~in a “Main Street” setting~~ to meet resident’s needs and to attract outside users and activities;
- Promote a “live-work” environment including residential above commercial spaces;
- Incorporate distinctive civic and quasi-public spaces for people to gather and to reinforce community identity; and
- Provide a village green as a visual centerpiece and a venue for a wide variety of activities such as farmer’s markets, arts and craft shows, various events and celebrations, and performance arts.

*Design:*

- Emphasize urban streetscapes as a predominant design element bringing buildings and activities to the sidewalk to create a vertical enclosure that defines comfortable public spaces;
- Incorporate deciduous tree canopies, coordinated street furnishings, plazas and multi-use spaces, pedestrian scale lighting, directional signage and other elements to enhance the pedestrian environment;
- Provide gateways to create a sense of identity and arrival to the Village Center;
- Require street forward building orientations, entries, porches, windows and other elements to create visual interest and activity along the pedestrian ways;
- De-emphasize the visual presence of garages and off-street parking through rear oriented parking areas, alley access and by optimizing on-street parking to meet a portion of the parking demand; and
- Permit adequate flexibility to accommodate the variety of specific product types and design solutions that contribute to the realization of the Village Center.

The Village Center presents a distinctive development form, characterized by a grid-like street network and buildings that are oriented to streets, that may challenge certain established attitudes and conventions. As a result, it is critical to maintain a determined commitment to the components and principles that define the Village Center, with recognition of long-term goals over short-term market pressures.



### 10.3 LAND USE PLAN & REGULATIONS

#### □ OVERVIEW

The Village Center includes a mix of residential, commercial, park and public/quasi-public uses. All uses include the Village Center combining land use designation to recognize their unique nature and requirements. Village Center land uses are reflected on Figure 10-2, and are summarized on Table 10-1. A parcel-by-parcel land use, zoning, unit and square footage summary is included on Table 10-2.

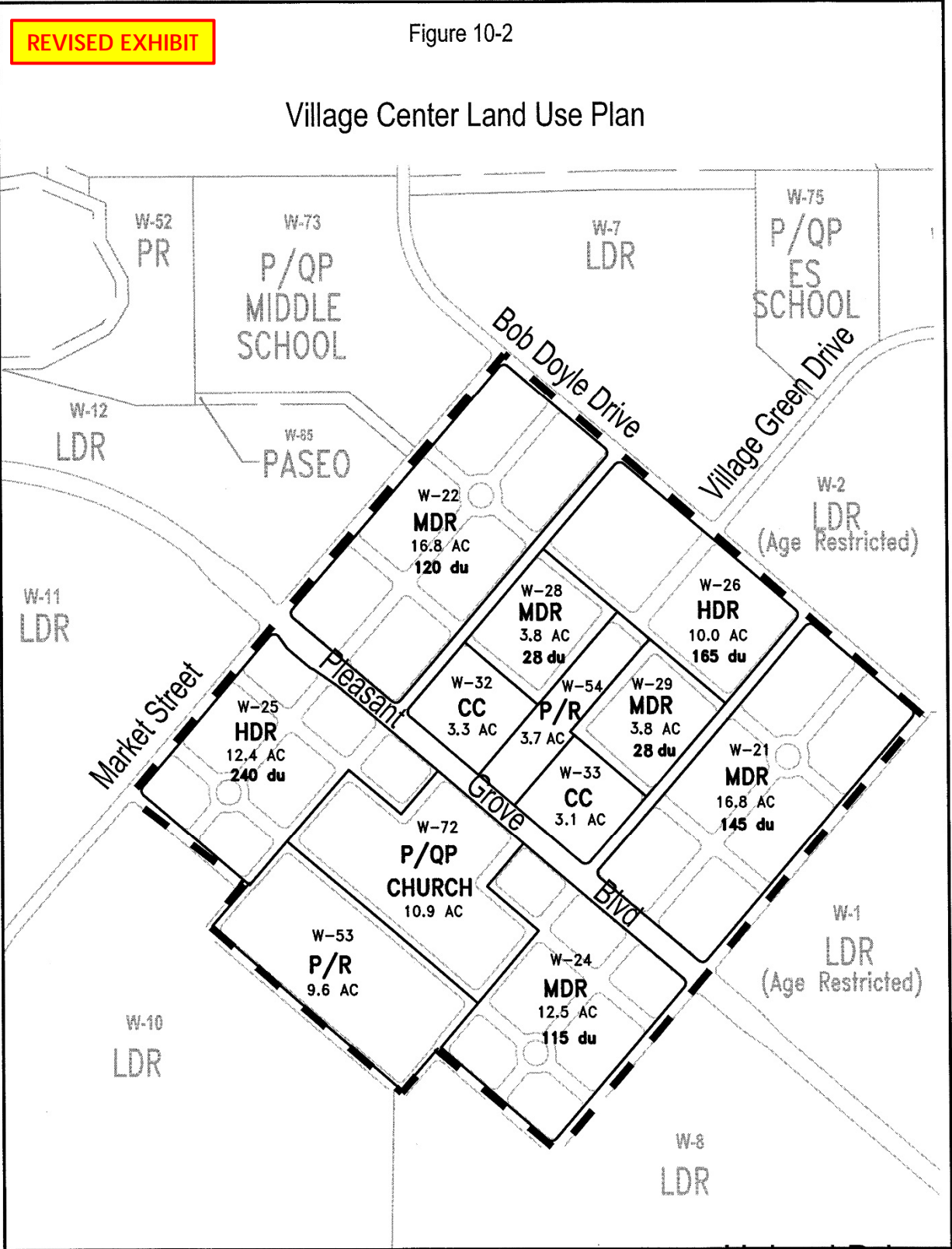
**Table 10-1: Village Center Land Use Summary**

General Plan Designation	Land Use	Acres	% of Total Acres	Units
VC - MDR	Medium Density Residential	<del>53.73</del> 46.10	<del>44%</del> 38%	<del>454</del> 391
VC - HDR	High Density Residential	<del>21.75</del> 22.44	<del>18%</del> 19%	<del>386</del> 405
VC - CC	Community Commercial	<del>6.41</del> 4.50	<del>5%</del> 4%	40
VC - P/R	Park & Recreation	<del>12.69</del> 13.78	11%	
VC - P/QP	Public/Quasi-Public	10.83	9%	
	Road Right of Way	<del>15.37</del> 13.13	<del>13%</del> 12%	
<b>TOTAL</b>		<b>120.78</b>	<b>100%</b>	<b>840</b> <del>836</del>

**Table 10-2: Village Center Land Use, Zoning, Units & Square Footage by Parcel**

Parcel #	Land Use	Zoning	Acres	Density <sup>1</sup>	Units <sup>2</sup>
W-21	VC-MDR	R3/DS	16.87 <del>5</del>	8.2 du/ac	138
W-22	VC-MDR	R3/DS	16.61	8.3 du/ac	138
W-24	VC-MDR	R3/DS	12.65 <del>4</del>	9.1 du/ac	122 <del>115</del>
W-25	VC-HDR	R3/DS	12.36 <del>45</del>	19.3 du/ac	232 <del>240</del>
W-26	VC-HDR	R3/DS	9.39 <del>99</del>	16.5 du/ac	154 <del>165</del>
<del>W-28</del>	<del>VC-MDR</del>	<del>R3RS/DS</del>	<del>3.80</del>	<del>7.4 du/ac</del>	<del>28</del>
<del>W-29</del>	<del>VC-MDR</del>	<del>R3RS/DS</del>	<del>3.80</del>	<del>7.4 du/ac</del>	<del>28</del>
W-32	VC-CC	CC/SA-WR	3.31 <del>7.24</del>		-20 <sup>3</sup>
W-33	VC-CC	CC/SA-WR	3.10 <del>7.26</del>		-20 <sup>3</sup>
W-53	VC-PR	P/R	8.98 <del>9.93</del>		
W-54	VC-PR	P/R	3.71 <del>3.85</del>		
W-72	VC-P/QP	P/QP/SA-WR	10.83		
Road Right-of-Way			15.37 <del>1313</del>		
<b>TOTAL</b>			<b>120.78</b>		<b>840<del>836</del></b>

1. A mix of unit types and resulting densities are anticipated. Identified densities reflect an average as applied to the entirety of each parcel.
2. The WRSP allows for Minor Density Adjustments for LDR and MDR Units. Confirm current unit counts with the City of Roseville Planning Department.
- ~~3. A total of 40 units are allocated to be spread between Parcels W-32 and/or W-33. The exact allocation of units between the two parcels shall be determined through the Design Review process.~~



**Note: Underlying parcel basemap used in this figure is not regularly updated. Refer to Figure 4-1 for the most up to date parcel basemap.**

**□ PERMITTED USES AND DEVELOPMENT STANDARDS**

Land uses within the Village Center are implemented through application of zone districts as specified by the City of Roseville Zoning Ordinance. In recognition of its distinctive form, the Development Standards (DS) or Special Area (SA) overlay zones have been applied to most Village Center Uses. The overlay zones customize development standards and/or permitted uses of general zone districts to reflect the unique nature of the Village Center. A summary of zoning districts and overlay zones applied to the Village Center is included in Table 10-3. Guidance relating to the application of these overlay zones is provided in this section.

The WRSP Design Guidelines (Section 12) include additional details to be considered in the design, review and approval of individual projects within the Village Center.

**Table 10-3: Summary of Village Center Applied Zoning Districts**

Land Use	Applied Zoning Districts	Permitted Uses	Development Standards
VC – MDR: <i>Medium Density Residential</i>	R3/DS & <del>RS/DS</del>	Per Zoning Ordinance	<b>Modified by WRSP<sup>1</sup></b>
VC – HDR: <i>High Density Residential</i>	R3/DS	Per Zoning Ordinance	<b>Modified by WRSP<sup>1</sup></b>
VC – CC: <i>Community Commercial</i>	CC/SA-WR	<b>Modified by WRSP<sup>1</sup></b>	<b>Modified by WRSP<sup>1</sup></b>
VC – P/R: <i>Parks &amp; Recreation</i>	P/R	Per Zoning Ordinance	Per Zoning Ordinance
VC – P/QP: <i>Public/Quasi-Public</i>	P/QP/SA-WR	<b>Modified by WRSP<sup>1</sup></b>	Per Zoning Ordinance

1. Section 10.3

**□ RESIDENTIAL USES**

A wide range of higher density single-family attached, detached and multi-family housing types are included and encouraged within the Village Center. Housing is to be of an urban nature with higher densities than found in a typical suburban setting. Densities within the Village Center will range from ~~7.4~~ **8.2** to over 19.3 units per acre, with an overall average density of approximately 12 units per acre. Emphasis is placed on defining the relationship between residential units and the street. Dwelling units are to be brought forward with entry doors and active living areas facing the street. ~~Generally,~~ off-street parking is to be de-emphasized through alley access and rear yard garages. The intent is to create an active, pedestrian friendly community environment reminiscent of a traditional neighborhood.

<b>Medium Density Residential (VC-MDR)</b>	
<b>Density Range:</b>	<b>7.0 to <del>13.0</del>12.9 dwelling units per acre</b>
<b>Applied Zoning District:</b>	<b>R3/DS: Attached or Detached Housing/Design Standard Overlay</b> <b><u>RS/DS: Small Lot Residential/Development Standard Overlay</u></b>
<b>Description:</b>	<p>Medium Density Residential (MDR) land use is anticipated to accommodate urban density housing with a strong orientation toward the street. Key components of any MDR unit type shall include:</p> <ul style="list-style-type: none"> <li>▪ Single family attached or detached units facing the public street</li> <li>▪ Entries/porches facing and moved forward towards the street</li> <li>▪ Alley loaded or recessed rear yard garages, <u>excluding Parcels W-28 and W-29</u></li> </ul> <p>The preferred model is the “brownstone” concept reflective of the above elements. Other anticipated unit types include townhomes, and single-family detached. Figures 10-3 through 10-5<sub>a</sub> include illustrative layouts for potential unit types. There are other unit types that may be accommodated within the MDR land use and achieve the Planning Principles for the Village Center. All unit types shall be consistent with the R3/DS development standards, <u>as well as the RS/DS development standards for parcels W-28 and W-29</u>, and the WRSP Design Guidelines.</p> <p>Table 10-2 includes specific unit allocations and resulting densities for each MDR parcel. While it is anticipated and encouraged that unit types be mixed on a large lot parcel, the overall density in the Village Center shall average that prescribed on Table 10-2. In no case may a specific unit type on any MDR large lot parcel be below or above the density range specified by the MDR land use (7.0 to 12.9 du/ac).</p>
<b>Permitted Uses:</b>	As specified in the City of Roseville Zoning Ordinance.
<b>Development Standards:</b>	<p>The Design Standard (DS) Overlay provides for the unique nature and variety of housing types anticipated in the Village Center and the MDR density range. Development standards are included on Table 10-4. Standards are specified for both detached and attached units. Product types, building footprints (with associated fit lists) and architectural design of units shall be approved <u>pursuant to the Application Review Process outlined in the City’s adopted Community Design Guidelines for Compact Residential Development, with the tentative small lot subdivision map for each Village Center large lot parcel.</u> Modifications to the approved architectural design of units may subsequently be approved administratively if in compliance with Table 10-4. Other product types consistent with the intent of the Village Center development standards and Design Guidelines may be considered subject to approval of a Design Review Permit for Residential Subdivisions (DRRS) concurrent with approval of a tentative subdivision map.</p>

Figure 10-3: Village Center MDR (R3/DS) Brownstone-Picture and Plan View

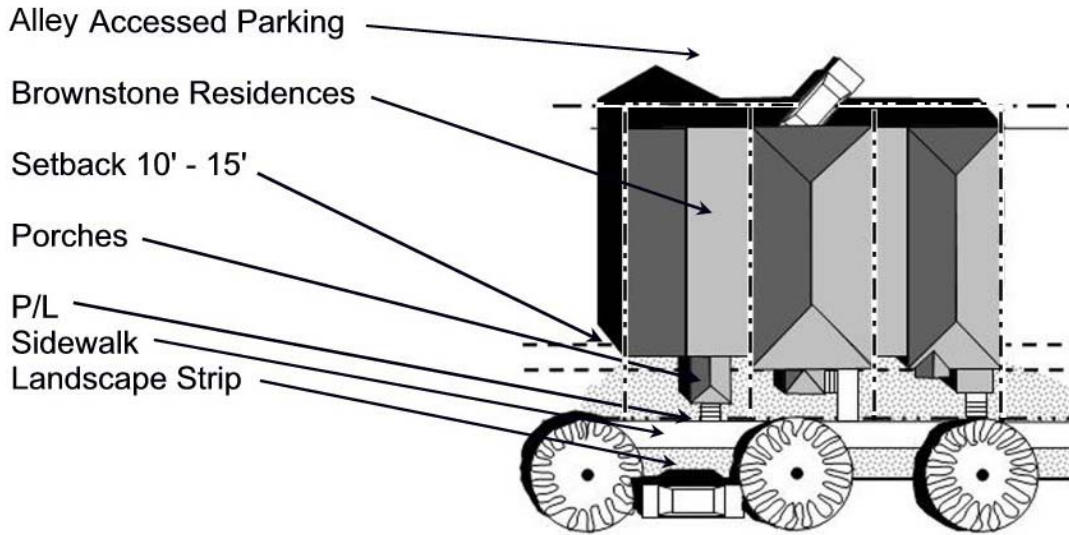


Figure 10-4: Village Center MDR (R3/DS) Townhouse-Picture and Plan View

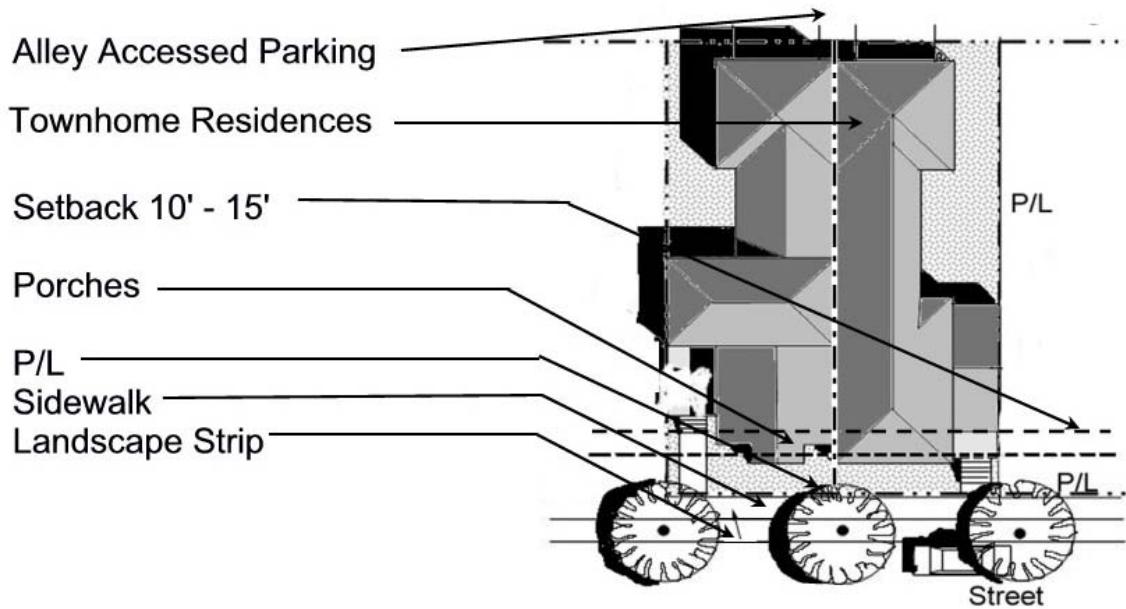
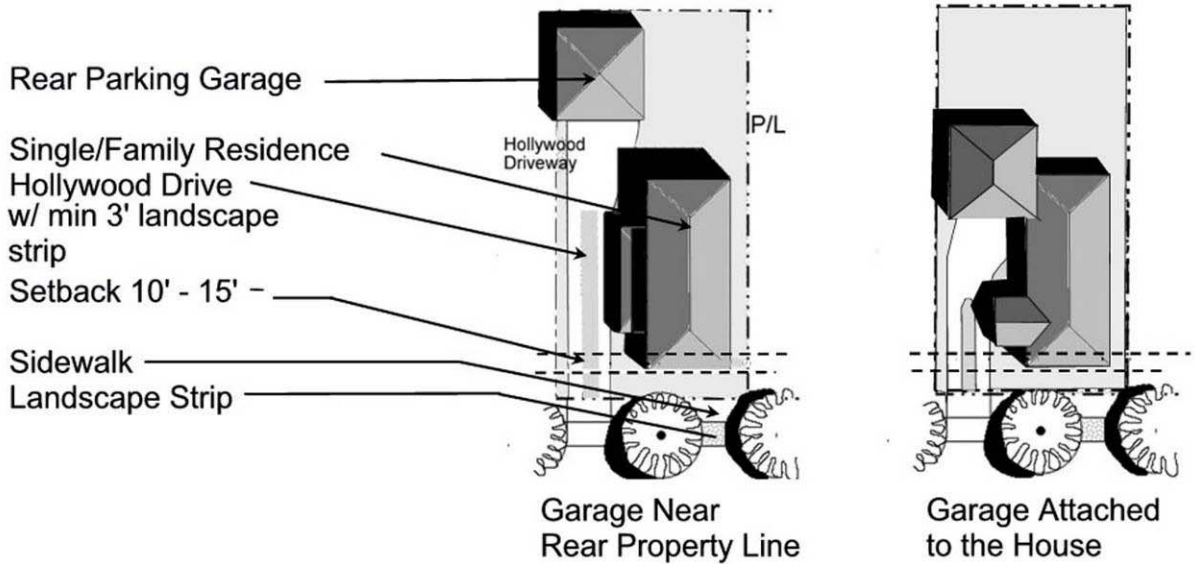
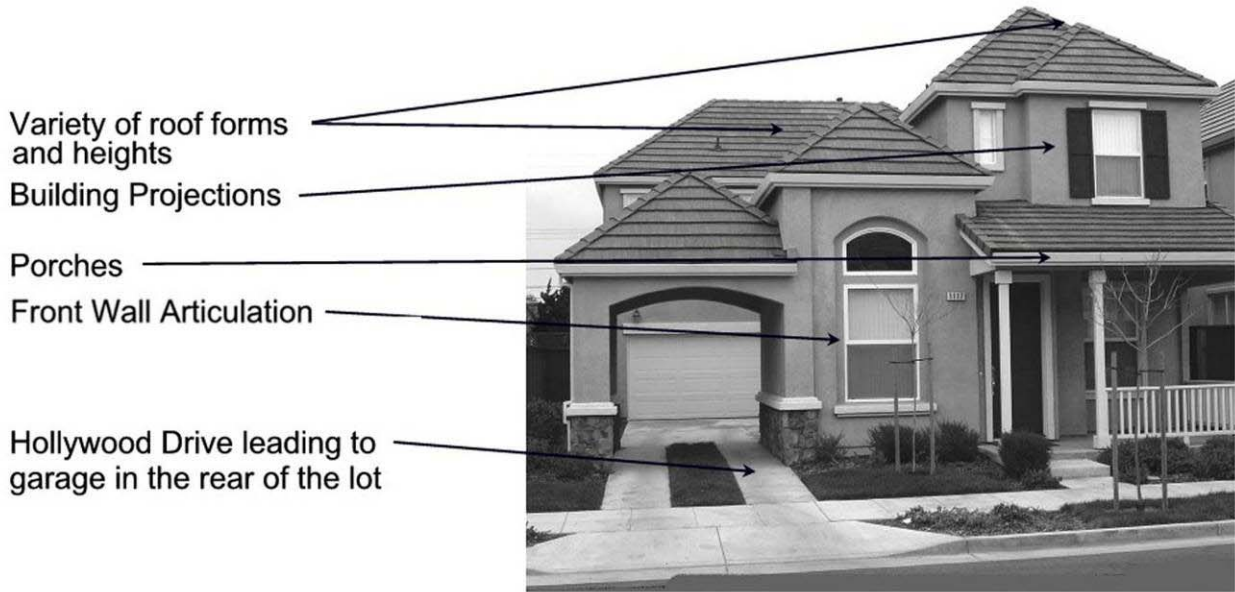


Figure 10-5: Village Center MDR (R3/DS) Single Family Detached-Picture and Plan View



**Table 10-4a: Village Center MDR Development Standards for RS/DS (Parcels W-28 & W-29)**

**[NEW TABLE]**

<b>RS/DS Development Standards (MDR)</b>		
<b>Product Type</b>		
	Single Family with Attached Sidewalk <sup>4</sup>	Single Family with Separated Sidewalk <sup>1,4</sup>
<b>Lot Size (minimum)</b>		
Area, Interior Lot	3,600 sq. ft.	3,600 sq. ft. <sup>1</sup>
Area, Corner Lot	4,400 sq. ft.	4,000 sq. ft. <sup>1</sup>
Width, Interior	45 ft.	45 ft.
Width, Corner	55 ft.	50 ft.
<b>Permitted Density (maximum per lot)</b>		
Residential Density	1 dwelling; 1 second unit	1 dwelling; 1 second unit
<b>Setbacks (minimum)</b>		
Front <sup>2</sup>	15 ft. to living space or side wall of garage; 12.5 ft. to porch 18 ft. min. driveway depth with roll-up garage	10 ft. to first-floor living space or side wall of garage 7.5 ft. to porch, but in no case may encroach into a PUE 15 ft. to second-floor living space 18 ft. min. driveway depth with roll up garage
Sides <sup>2</sup> Interior Lots: Corner Lots:	5 ft. 5 ft. interior side 12.5 ft. street side on first floor 15 ft. street side on second floor	5 ft. 5 ft. interior side 10 ft. street side on first floor 13 ft. street side on second floor
Rear	10 ft. minimum with minimum usable open space of 700 s.f. or 500 s.f. where a usable front porch is provided <sup>3</sup>	10 ft. minimum with minimum usable open space of 500 s.f. where a usable front porch is provided <sup>3,3</sup>
<b>Coverage (maximum)</b>		
Site Coverage	None <sup>3</sup>	None <sup>3</sup>
<b>Height (maximum)</b>		
Height	35 ft.	35 ft.
<b>Supplemental Design Standards</b>		
1. Front Yard Stagger	None required, but optional per unit design	
2. Stagger for 3 <sup>rd</sup> Car Garages	2 ft. between 3 <sup>rd</sup> car bay and two-car garage	
3. Two-story unit mix	No limit	
4. Separation Between Second Story Elements	A minimum of 10 feet shall be provided between second story elements of adjacent two-story dwellings	
5. Building Exterior	Architectural treatment shall be applied to all elevations of a building. At a minimum, all doors, windows and other wall openings shall be trimmed consistent with the architectural style, consistent with the Compact Residential Design Guidelines provided in the City's adopted Community Design Guidelines. Panelized windows or other architectural treatment shall be used on all garage doors.	

- 1 Sidewalk separated from back of curb by 6-foot planter strip
- 2 Front setback (and side setback where adjacent to street) is measured from back of walk. Fence side yard setback is 5' from back of walk where facing a street. In the absence of a sidewalk, setback is measured from edge of right-of-way.
- 3 The rear and side yards may be utilized to meet the minimum usable open space provided the minimum dimension, measured perpendicular to the applicable rear or side yard is ten (10) feet. Maximum coverage is a function of lot size, required setbacks and usable open space. A minimum usable open space of 500 s.f. may be applied where a front porch is provided with minimum dimension of 6 ft. x 10 ft. exclusive of entry way.
4. Variations to the standards and other housing product types may be permitted through approval of a Design Review Permit for Residential Subdivisions (DRRS).

Figure 10-5a: Village Center MDR (RS/DS) Single Family Detached Plan Details

NEW FIGURE



**Figure 10-5b: Village Center MDR (RS/DS) Single Family Side Elevation Details****NEW FIGURE****Additional design requirements for side elevations:**

All exterior building elevations that face a public street, including side elevations, shall incorporate enhanced architectural design features, which may include building articulation, recesses, or other stylistic elements that enrich the visual design of the facade. Examples of homes with enhanced side elevations are provided below:



Figure 10-6: Front Driveway Prohibited Access Locations

REVISED EXHIBIT

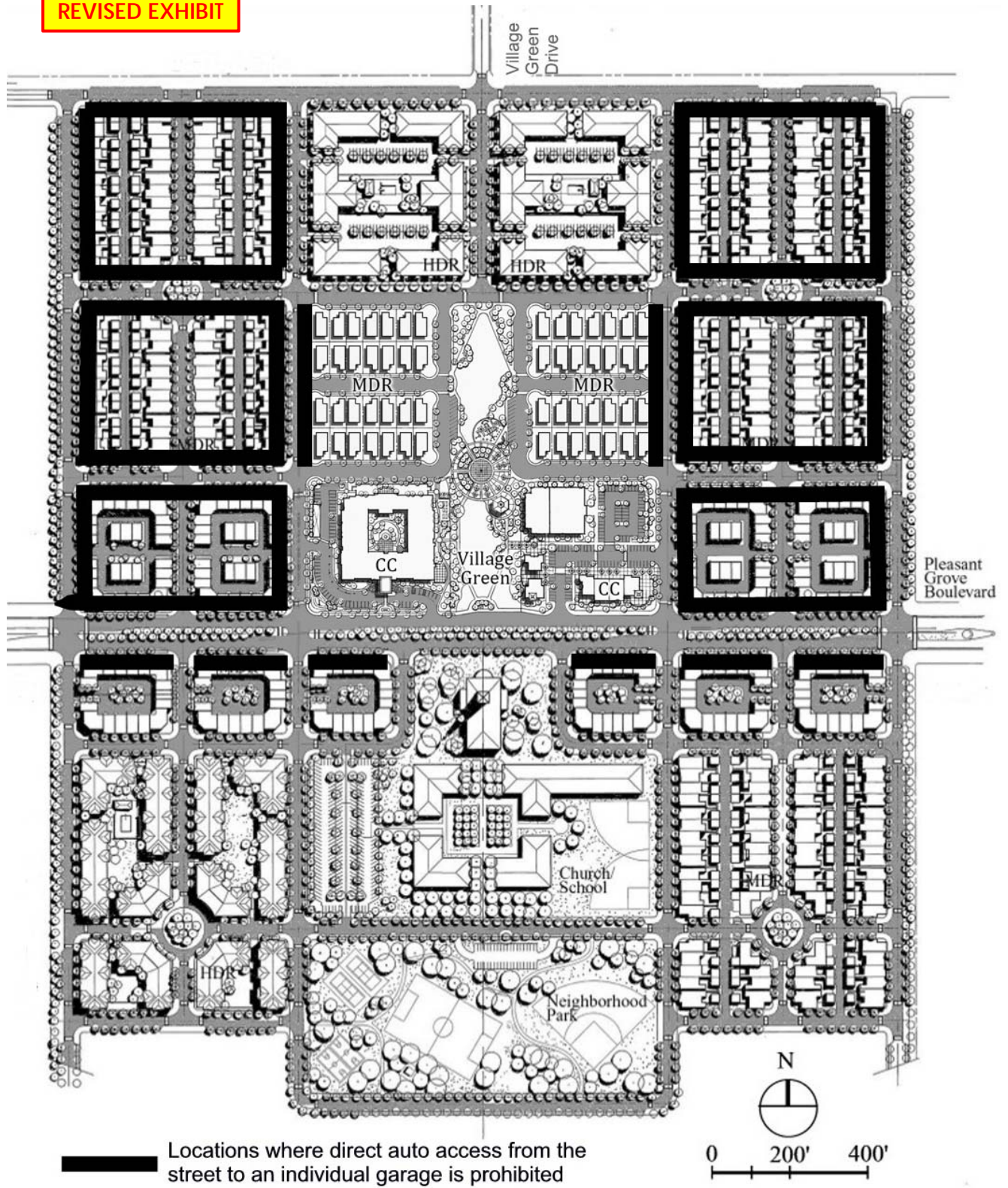
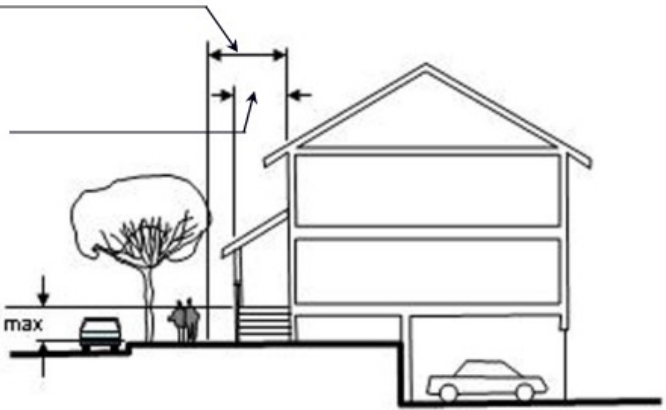


Figure 10-7: Village Center MDR (R3/DS) Front Setback-Cross Sections

Front setback min. of 10' & maximum of 15' from front P/L

Open porches may project into the front yard setback a maximum of 6'

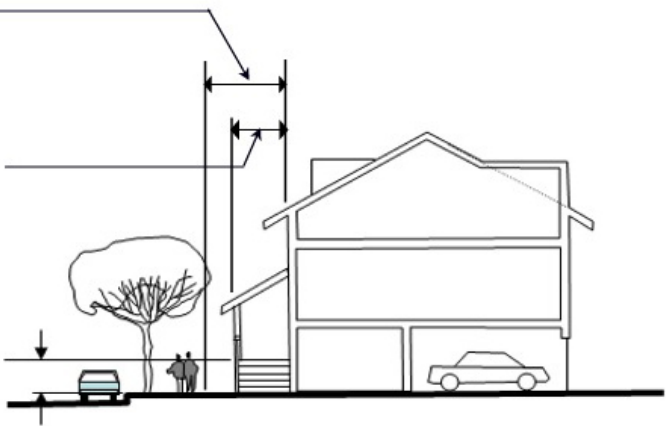
Maximum height of the porch not to exceed 4'-6" above the adjacent curb



Front setback min. of 10' & maximum of 15' from front P/L

Open porches may project into the front yard setback a maximum of 6'

Maximum height of the porch not to exceed 4'-6" above the adjacent curb



**□ RETAIL & SERVICE USES**

The integration of commercial land use that can accommodate retail businesses, service uses and community activities is a critical component of the Village Center and a central focus of its design. These uses, in combination with adjacent and mixed residential and public uses, create a diverse community with a variety of options that promote interaction. Both businesses and residents benefit from the proximity of uses, increasing the viability of walking, bicycling and transit as transportation options.

Similar to residential uses, emphasis is placed on the relationship of buildings to the street. Building facades are oriented to the street ~~and located adjacent to the sidewalk~~. Off-street parking is located to minimize visibility from public streets ~~on well designed lots to the rear of the stores~~. On-street parking is maximized to provide a visual parking presence while meeting a portion of the parking demand for the retail component of the Village Center. Numerous design elements, such as transparent storefronts, wide sidewalks, traditional style lighting, dense tree canopies, and coordinated street furnishings are provided to create a comfortable and distinctive “main street” setting. Restaurant seating, and other accessory services, are permitted to encroach onto public spaces to enhance an active pedestrian friendly environment and encourage social activity.:

Community Commercial (VC-CC)	
<b>Applied Zoning District:</b>	<b>CC/SA-WR: Community Commercial/Special Area Overlay</b>
<b>Description:</b>	The Community Commercial (CC) land use is anticipated to accommodate a variety of retail and service activities. Typical uses may include retail shops, restaurants, local pubs, banks, grocery stores, convenience services, theaters and offices. These uses, within walking distance to and mixed with the Village Center residential, are planned to meet the everyday needs of local residents and promote non-vehicular forms of transportation. In addition, the commercial uses in the Village Center act to draw residents from throughout the community due to their unique form and setting.
<b>Permitted Uses:</b>	The Special Area (SA) overlay has been applied to modify permitted, conditionally permitted and administratively permitted uses. The intent is to provide for a unique mix of uses that support the Village Center concept. This includes permitting residential uses over commercial spaces to create live-work opportunities. In addition, in order to promote retail and other pedestrian attractive service activities along the streetscape, certain uses such as offices; <del>vocational schools and community assembly are restricted</del> (require a Conditional Use Permit) <del>on ground floor spaces</del> . Permitted uses are included on Table 10-6.
<b>Development Standards:</b>	Development standards have been modified by the Special Area (SA) overlay to provide for the distinctive nature of the Village Center. Development standards are included on Table 10-7. All commercial development is subject to City approval of an Administrative Permit, provided such development is consistent with the development and design standards contained in Table 10-7.



Table 10-6: CC/SA-WR Permitted Uses

AGRICULTURAL AND OPEN SPACE USE TYPES		CC/SA-WR
Resource Protection & Restoration		-
Resource Related Restoration		-
CIVIC USE TYPES		CC/SA-WR
Community Assembly		- P/CUP(1)
Community Service		- CUP
Essential Services		P
Hospital Services		
	General Hospital Services	-
	Psychiatric Hospital Services	-
Libraries & Museums, Private		P/CUP(1)
Public Parking Services		- P
Schools		
	College & University	P/CUP(1)
	Elementary & Secondary	-
	Private Elementary & Secondary	-
Social Services		
	Food Distribution	-
	Food Service	-
	Temporary Resident Shelter	-

RESIDENTIAL USE TYPES		CC/SA-WR
<b>Caretaker/Employee Housing</b>		-
<b>Dwelling</b>		
	Multi-Family	P <sub>(2)</sub>
	Single-Family	-
	Two-Family	-
<b>Family Day Care Home, Small</b>		-
<b>Family Day Care Home, Large</b>		-
<b>Single Room Occupant</b>		-

COMMERCIAL USE TYPES		CC/SA-WR
<b>Adult Business Establishments</b> <sup>(3)</sup>		-
<b>Animal Sales &amp; Services</b>		
	Grooming & Pet Stores	P
	Kennels	-
	Veterinary Clinics	P
	Veterinary Hospital	-
<b>Automotive &amp; Equipment</b>		
	Automotive Rentals	-
	Automotive Repairs	-
	Automotive Sales	-
	Car Wash and Detailing	-
	Commercial Parking	-
	Heavy Equipment Rental, Repair and Sales	-
	Equipment Repair	-
	Gasoline Sales	-
<b>Banks &amp; Financial Services</b> <sup>(3)</sup>		P
<b>Bars &amp; Drinking Places</b>		P
<b>Broadcasting and Recording Studios</b>		-
<b>Building Materials Stores</b>		-
<b>Business Support Services</b>		P
<b>Commercial Recreation</b>		
	Amusement Center	P
	Indoor Entertainment	P
	Indoor Sports and Recreation	P
	Outdoor Entertainment	-
	Outdoor Sports and Recreation	-
	Large Amusement Complexes	-
<b>Community Care Facility</b> <sup>(1)</sup>		<del>-P</del>
<b>Day Care Center</b>		<del>-P</del>
<b>Eating and Drinking Establishment</b>		
	Fast Food with Drive Through	-
	Convenience	P
	Full Service	P
<b>Food &amp; Beverage Retail Sales</b>		P
<b>Funeral &amp; Internment Services</b>		-
<b>Lodging Services</b>		<del>-P/CUP(1)</del>
<b>Long Term Care Facility</b>		-
<b>Maintenance and Repair</b>		P
<b>Medical Services</b>		
	General	<del>P/CUP(1)</del>
	Substance Abuse Treatment Clinic	-
COMMERCIAL USE TYPES (cont.)		CC/SA-WR
<b>Neighborhood Commercial</b>		-
<b>Nightclubs</b> <sup>(4)</sup>		-
<b>Nursery, Retail</b>		-
<b>Offices, Professional</b> <sup>(3) (4)</sup>		<del>P/CUP</del>
<b>Personal Services</b> <sup>(5)</sup>		P
<b>Retail Sales and Services</b> <sup>(3) (6)</sup>		P
<b>Specialized Education &amp; Training</b>		
	Vocational Schools	<del>P/CUP(1)</del>
	Specialty Schools	<del>P/CUP(1)</del>

<b>Storage, Personal Storage Facility</b>	-
<b>INDUSTRIAL USE TYPES</b>	
<b>Laundries, Commercial</b>	-
<b>Printing &amp; Publishing</b>	-
<b>Research Services</b>	-
<b>Wholesale &amp; Distribution, Light</b>	-
<b>TRANSPORTATION AND COMMUNICATION USE TYPES</b>	
<b>Antennas &amp; Communications Facilities<sup>(5)</sup></b>	-
Developed Lot	-
Undeveloped Lot	-
<b>Heliport</b>	-
<b>Intermodal Facilities<sup>(6)</sup></b>	-

All highlighted uses have been modified by the WRSP SA Overlay.

- (P) Principally Permitted
- (CUP) Permitted through approval of a Conditional Use Permit
- (A) Administratively Permitted
- (-) Not Permitted

**Notes:**

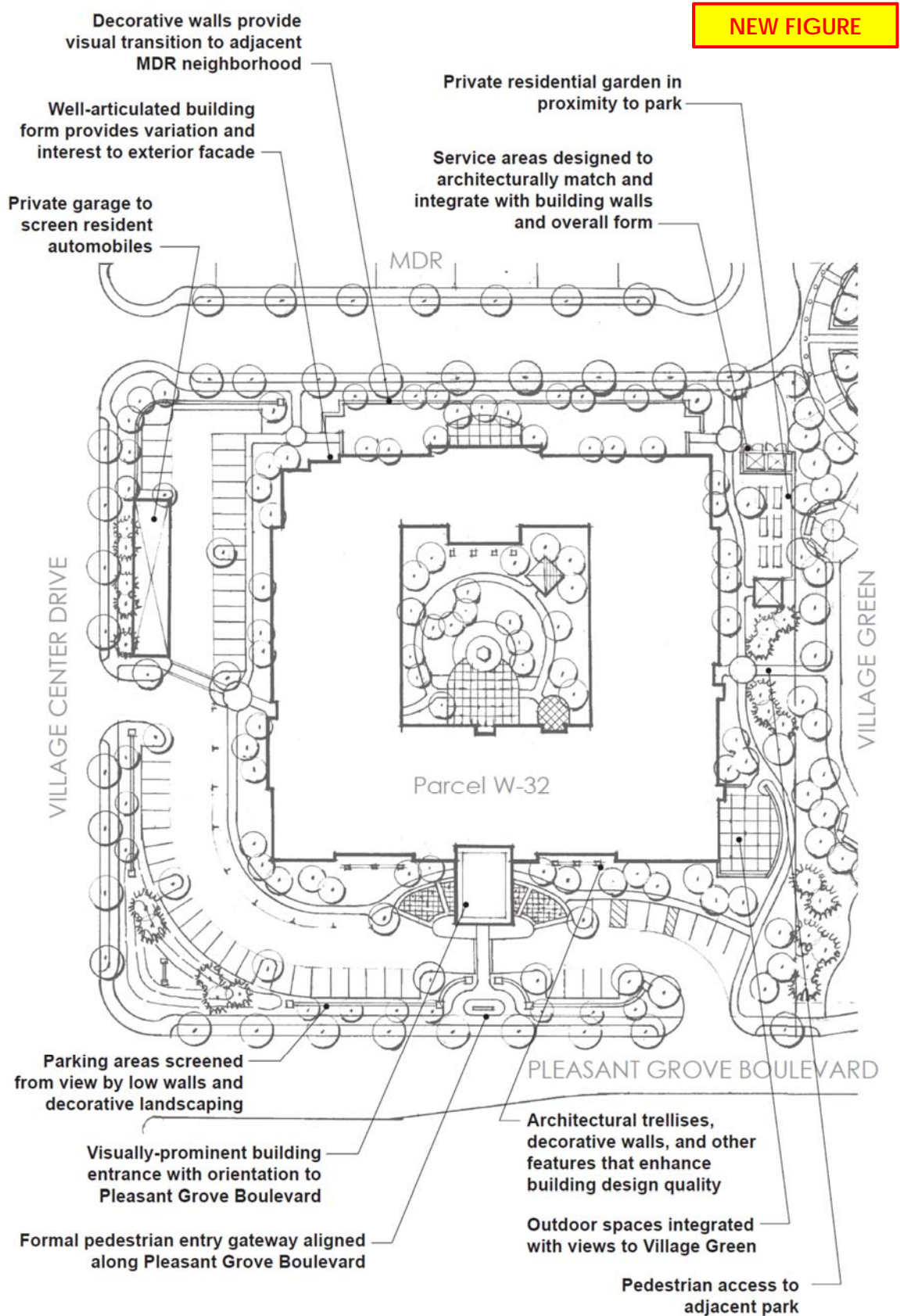
- ~~(1) Permitted by right on second floor, Conditional Use Permit required on ground floor.~~
- ~~(1) Permitted only on Parcel W-32.~~
- ~~(2) Permitted on second floor only.~~
- ~~(3) Cash advance and bail bonds are not permitted uses within the Banks and Financial Services, Professional Office and Retail Sales and Services use types.~~
- ~~(4) A maximum of 25 percent of the total square footage developed on Parcel W-33 can include Professional Office Uses on the ground floor.~~
- ~~(5) Tattoo shops and body piercing shops are not permitted uses within the Personal Services use type.~~
- ~~(6) Smoke shops, hookah lounges and smoking lounges are not permitted uses within the Retail Sales and Services use type.~~
- ~~(2) Additional Requirements contained in Chapter 19.32 of the City of Roseville Zoning Ordinance~~
- ~~(3) Additional Requirements contained in Chapter 19.49 of the City of Roseville Zoning Ordinance~~
- ~~(4) Additional Requirements contained in Chapter 19.34 of the City of Roseville Zoning Ordinance~~
- ~~(5) Additional Requirements contained in Chapter 19.36 of the City of Roseville Zoning Ordinance~~

**Table 10-7a: Modified CC Development & Design Standards for Parcel W-32**  
**[THIS IS A NEW TABLE THAT REPLACES THE PREVIOUS DEVELOPMENT STANDARDS]**

CC/SA-WR Development & Design Standards for Parcel W-32	
<b>Sidewalks</b>	
<b>Design Intent: To provide adequate space to accommodate and promote pedestrian related activity.</b>	
Sidewalks	Pleasant Grove Boulevard: 8-foot minimum, attached to back of curb Village Center Drive: 6-foot minimum, detached from curb by 6'-wide planter strip
<b>Building Setbacks</b>	
<b>Design Intent: To ensure that buildings have a strong visual presence along major streets</b>	
Front/ Pleasant Grove Blvd.	20-foot from back of curb minimum
Side & Rear	Adjacent to Street – 12.5-foot from back of sidewalk Adjacent to Village Green Park – 10-foot from property line abutting park
Decorative Walls	5-foot minimum from back of sidewalk
<b>Entries, Building Articulation, &amp; Architectural Features</b>	
<b>Design Intent: To ensure that building entrances are highly-visible along primary street frontages and that building architecture incorporates traditional elements such as a base/bulkhead, body with windows, and roofline/cornice, which create visual interest and high-quality architecture.</b>	
Entries	Primary building entrances facing Pleasant Grove Boulevard or Village Center Drive shall be clearly articulated and discernable elements of the building.
Building Articulation	Street-facing facades (or within public view) shall be well articulated through the use of a variety of roof forms, building projections and recesses, window styles, decorative trim, awnings, cornice and belt courses, paint colors, and/or finish materials;  Corner parcels are encouraged to incorporate rounded or cut corners and other architectural features. Added height at corner elements is permitted to create a focal point (see Height Exception Standards below).
Rooflines	Shall be varied and capped with a strong cornice line, roof treatment or combination of treatments.
Side/Rear Facades	Building facades not facing primary street frontages shall be designed to present an inviting façade to adjacent parcels and surrounding streets;  Service doors and areas shall be architecturally designed as an integral part of the building.
Lighting	Shall be designed as an integral part of the building façade to provide an ambient level of light on the street. Lighting may provide low-level wash on the face of the building.
<b>Height</b>	
<b>Design Intent: To create building walls and massing that define, but do not overwhelm, public spaces.</b>	
Height Limit	35-foot maximum;
Exceptions	Towers, cupolas, steeples, dormers, spires, flagpoles, and similar architectural elements if the element is integrated into the overall architectural design and occurs at significant locations, such as at primary building entrances or building corners.

<b>CC/SA-WR Development &amp; Design Standards for Parcel W-32</b>	
<b>Parking</b>	
<b><i>Design Intent: To provide adequate parking while minimizing the visual impacts of off-street parking areas.</i></b>	
Off-Street Parking	Per requirements of City of Roseville Zoning Ordinance.
Screening	The perimeter of off-street parking areas abutting a street shall have a minimum 6-foot wide landscape setback consisting of any combination of a low concrete/masonry wall, landscaped berm, and/or hedge that is 4-feet high.

Figure 10-10: Concept Plan for Commercial Parcel W-32



**Figure 10-11: Design Elements for Commercial Buildings on Parcel W-32**

**NEW FIGURE**

Articulated massing creates smaller building forms that add architectural diversity

Varied roof lines respond to different building forms

Use of color and trim elements enhance visual appearance

Building entrance defined with prominent architectural feature

Design incorporates distinct base and body elements



Windows incorporate shutters or other design elements to highlight their appearance

Decorative trellises enhance appearance of building facade

Outdoor patio areas provide semi-private spaces for seating

Low, decorative walls visually define public realm from private spaces



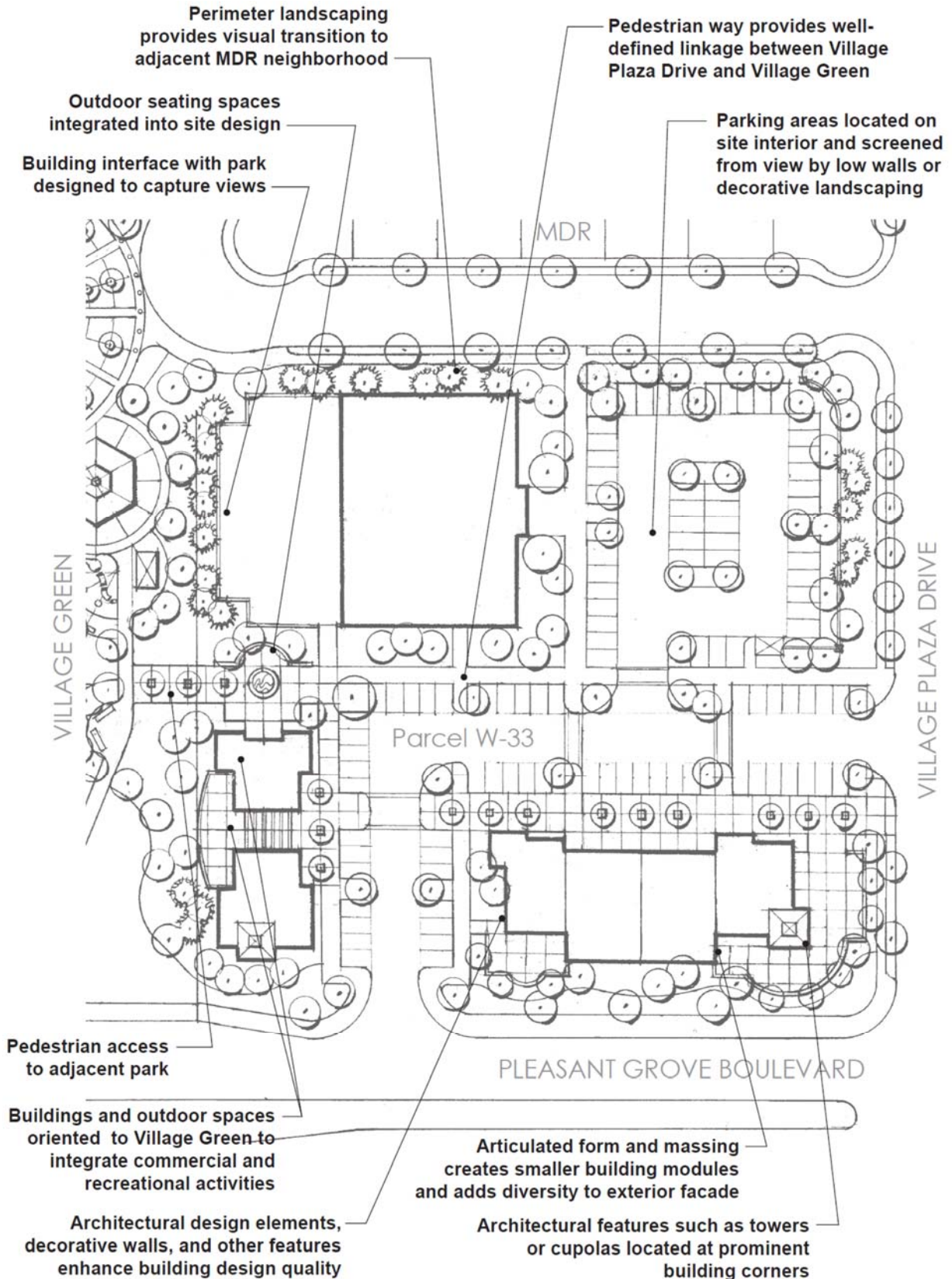
**Table 10-7b: Modified CC Development & Design Standards for Parcel W-33**  
**[THIS IS A NEW TABLE THAT REPLACES THE PREVIOUS STANDARDS]**

CC/SA-WR Development & Design Standards for Parcel W-33	
<b>Sidewalks</b>	
<b>Design Intent: To provide adequate space to accommodate and promote pedestrian related activity.</b>	
Sidewalks	Pleasant Grove Boulevard: 8-feet minimum, attached to back of curb Village Plaza Drive.: 6-feet minimum, detached from curb by 6- foot-wide planter strip
<b>Building Setbacks</b>	
<b>Design Intent: To ensure that buildings and associated activities are pulled forward toward the sidewalk and street to create a defined street edge.</b>	
Front/ Pleasant Grove Setback	20-feet from back of curb (8 foot attached walk and 12 foot landscaped planter).
Front Parking Setback	Minimum 6-foot landscape setback from back of sidewalk with screening. See Parking Screening Standards below.
Side & Rear Setbacks	Adjacent to Street – 12.5-feet from back of sidewalk Adjacent to Park – 10-feet
<b>Entries, Building Articulation, &amp; Architectural Features</b>	
<b>Design Intent: To ensure that entrances are well-defined elements of building design, that activity spaces are visually prominent and relate to building function, and that building architecture incorporates traditional elements such as a base/bulkhead, body with windows, and roofline/cornice, which create visual interest and high-quality architecture.</b>	
Entries	Entries shall be clearly articulated and discernable elements of the building design. Porticos are encouraged to help define retail entries, where appropriate for the architectural style.
Building Articulation	Exterior building design shall be well articulated through the use of a variety of roof forms, building projections and recesses, window styles, decorative trim, awnings, cornice and belt courses, paint colors, and/or finish materials;  Corner parcels are encouraged to incorporate rounded or cut corners, towers, or other architectural features that enhance the architectural quality of the building. Added height at corner elements is permitted to create a focal point (see Height Exception Standards below).
Rooflines	Shall be varied and capped with a strong cornice line, roof treatment or combination of treatments.
Awnings	Are encouraged as an element of building architecture and shall maintain a minimum clearance of 9-feet above the sidewalk.
Signage	Shall complement the style of architecture and be integrated into the building’s design; Acceptable sign types include, halo, lit or reverse pan channel, and indirectly lit panel signs;  Internally illuminated cabinet signs, pan channel signs and exposed railways are prohibited;  Blade or shingle-type signs are encouraged under canopies and awnings as close as practical to the horizontal middle of the building;
Side/Rear Facades	Building facades not facing primary street frontages shall be designed to present an inviting façade to adjacent parcels and surrounding streets;

<b>CC/SA-WR Development &amp; Design Standards for Parcel W-33</b>	
	Service doors and areas shall be designed as an integral part of the architectural building façade.
Lighting	Shall be designed as an integral part of the building façade to provide an ambient level of light. Lighting may provide low-level wash on the face of the building.
Service Entries	Service or delivery entries should be discouraged along the interface with the park. If located along this edge, these entries shall be architecturally integrated into the building design such that they do not appear as “back” doors.
<b>Height</b>	
<b>Design Intent: <i>To create building walls and massing that define, but do not overwhelm, the public spaces.</i></b>	
Height Limit	35-feet maximum; In no case shall the top of a building parapet or roof façade along the storefront be less than 16-feet.
Exceptions	Towers, cupolas, steeples, dormers, spires, flagpoles, and similar architectural elements if the element is integrated into the overall architectural design and occurs at significant locations, such as at primary building entrances or at building corners.
<b>Pedestrian Ways/Plazas</b>	
<b>Design Intent: <i>To link the individual commercial buildings to the off-street parking areas and to provide a clearly-defined pedestrian connection from the retail center to the Village Green.</i></b>	
Location	An internal pedestrian way is encouraged between the off-street parking areas, Village Plaza Drive, and the Village Green. The pedestrian ways should be clearly defined through the use of sidewalks, planters, or other site features that are visually prominent in the retail center. Outdoor plazas or seating areas are encouraged as part of site design to enhance building architecture and visually activate building edges and park interface.
Width	Pedestrian ways shall have a minimum width of 6-feet and a maximum width of 25-feet.
Treatment	Paving, landscaping and illumination along pedestrian ways shall be designed with site landscape architecture; Porticos or trellises are encouraged to help define pedestrian ways.
<b>Parking</b>	
<b>Design Intent: <i>To provide adequate parking while minimizing the visual impacts of off-street parking areas.</i></b>	
Off-Street Parking	Per requirements of City of Roseville Zoning Ordinance.
Screening	The perimeter of off-street parking areas abutting a street shall have a minimum 6-foot wide landscape setback consisting of any combination of a low concrete/masonry wall, landscaped berm, and/or hedge that is 4-feet high.

Figure 10-12: Concept Plan for Commercial Parcel W-33

NEW FIGURE



**Figure 10-13: Design Elements for Commercial Buildings on Parcel W-33**

**NEW FIGURE**

- Varied roof lines respond to different building forms
- Articulated massing creates smaller building forms that add architectural diversity
- Building entrance defined with prominent architectural feature



- Design incorporates distinct base, body, and cap facade elements
- Decorative awnings, lighting and other features enhance appearance of building facade
- Variation in building colors reinforce architectural style



- Building form and massing incorporates towers or other articulated elements that strengthen architectural style
- Outdoor patio areas provide semi-private spaces for seating
- Low, decorative walls visually define public realm from private spaces



[THE ORIGINAL CC/SA DEVELOPMENT STANDARDS BELOW HAVE BEEN REPLACED WITH THE NEW DEVELOPMENT STANDARDS LISTED IN TABLES 10-7A AND 10-7B, ABOVE]

<b>CC/SA-WR Development &amp; Design Standards</b>	
<b>Sidewalks</b>	
<b>Design Intent: To provide adequate space to accommodate and promote pedestrian related activity.</b>	
-Sidewalks	Minimum of 14 feet in width as measured from back of curb to the build to line; Sidewalks shall be decoratively paved with a pattern of unit pavers and colored concrete;  Utility appurtenances located in sidewalks shall be avoided. Where required, they shall be integrated with the paving pattern to the extent feasible.
<b>Setbacks</b>	
<b>Design Intent: To ensure that buildings and associated activities are pulled forward toward the sidewalk and street.</b>	
-Front Building -Build to Line -(Figure 10-10)	Back of sidewalk (14 feet from back of curb); All building facades facing the street shall be built up to the build to line.
Front Parking Setback	Minimum 6-foot landscape setback from back of sidewalk with screening. See Parking Screening Standards below.
Side & Rear Building Setbacks	Adjacent to Street – Front Build to Line Interior—None (zero side yard setbacks)
<b>Entries, Recesses and Projections</b>	
<b>Design Intent: To focus activity to the street and create inviting and highly accessible store fronts and activity spaces.</b>	
Entries	All buildings abutting Village Green Drive, Village Green Drive East or Village Green Drive West shall have their primary entry facing the street;  Entrances shall not be spaced more than 50 feet apart along the length of the frontage.
Front Entry Recesses (Figure 10-10)	Maximum of 6 feet behind build to line (away from back of walk) for storefront entries with the width of the recess not to exceed 10 feet.
Front Building Recesses (Figures 10-10 & 10-11)	Maximum of 10 feet behind the build to line (away from back of walk) to provide for active outdoor uses (dining, seating, etc.) that are covered and oriented to the sidewalk and street.
Front Non-Building Projections (Figures 10-10 & 10-11)	Maximum of 5 feet beyond the build to line (sidewalk) to accommodate outdoor dining; The grade elevation of a projection shall be at the same level as the adjacent sidewalk;  No permanent structures are allowed within the projection with the exception of ADA accommodations;  A separation between outdoor dining areas and the sidewalk may be provided through low planters or other removable barriers no more than 4 feet in height.
<b>Building Articulation</b>	
<b>Design Intent: To create a mix of architectural styles that incorporate three traditional elements: base (bulkhead), body (storefront with windows) and cap (roofline/cornice). Building facades should emulate the character and composition of retail/commercial buildings typically found in small towns, define the open space of the street and achieve quality retail space.</b>	
Street Facades (Figure 10-12)	The front or street facade shall be well articulated using a variety of architectural elements including a variety of roof forms, building projections and recesses, window styles, balconies, decorative trim, flower boxes, awnings, cornice and belt courses, paint colors, and multiple finish materials;

<b>CC/SA-WR Development &amp; Design Standards</b>	
	Corner parcels are encouraged to incorporate rounded or cut corners, special display windows, outdoor cafes, and other architectural features. Added height at corner elements is permitted to create a focal point (see Height Exception Standards below).

CC/SA-WR Development & Design Standards	
Store Fronts (Figure 10-12)	<p>For those buildings fronting the build-to-line (sidewalk), 75% of the ground floor street facade shall be windows or transparent with the ability to see into the store. The use of tinted or reflective glass is prohibited;</p> <p>Window bulkheads shall not exceed 30 inches in height;</p> <p>No building abutting Village Green Drive, Village Green Drive East or Village Green Drive West shall have a blank wall exceeding 10 feet in length along the street;</p> <p>Solid or grilled roll-down gates in front of storefronts are prohibited.</p>
Upper Floors (Figure 10-12)	<p>Shall be built to front build-to-line (sidewalk) and distinguished from ground floor storefronts through the use of a strong belt course or architectural expression line.</p>
Rooflines (Figure 10-12)	<p>Shall be varied and capped with a strong cornice line, roof treatment or combination of treatments.</p>
Bay Windows	<p>Ground Floor—May project 12 inches into the build-to-line (sidewalk) for a length not to exceed 12 feet.</p> <p>Upper Floors—May project up to 3 feet into the build-to-line (sidewalk) for a length not to exceed 10 feet. Shall maintain a minimum clearance of 15 feet above the sidewalk.</p>
Entry Porticos	<p>May project 12 inches into the build-to-line (sidewalk).</p>
Awnings	<p>May project up to 5 feet into the build-to-line (sidewalk) and shall maintain a minimum clearance of 9 feet above the sidewalk.</p>
Flower Boxes & Hangings	<p>Flower boxes/planters may project up to 18 inches into the build-to-line (sidewalk) and shall not exceed 2 feet in height (unless used to define outdoor dining area);</p> <p>Hanging flowerpots may project up to 18 inches into the build-to-line (sidewalk) and shall maintain a minimum clearance of 8 feet above the sidewalk.</p>
Signage	<p>Shall complement the style of architecture and be integrated into the building's design;</p> <p>Acceptable sign types include, halo, lit or reverse pan channel, and indirectly lit panel signs;</p> <p>Internally illuminated cabinet signs, pan channel signs and exposed railways are prohibited;</p> <p>Blade or shingle type signs are encouraged under canopies and awnings as close as practical to the horizontal middle of the building;</p> <p>Signs may not project more than 4 feet horizontally into the build-to-line (sidewalk) and shall maintain a minimum clearance of 9 feet above the sidewalk.</p> <p>A maximum of 10% of the window area may be used for temporary signs.</p>
Rear Facades	<p>Building facades facing off street parking shall be designed to present an inviting façade to the parking area and surrounding street, and may include direct retail entrances;</p> <p>Service doors and areas shall be designed as an integral part of the architectural building façade.</p>
Lighting	<p>Shall be designed as an integral part of the building façade to provide an ambient level of light on the street front building façade. Lighting shall provide low level wash on the face of the building.</p>

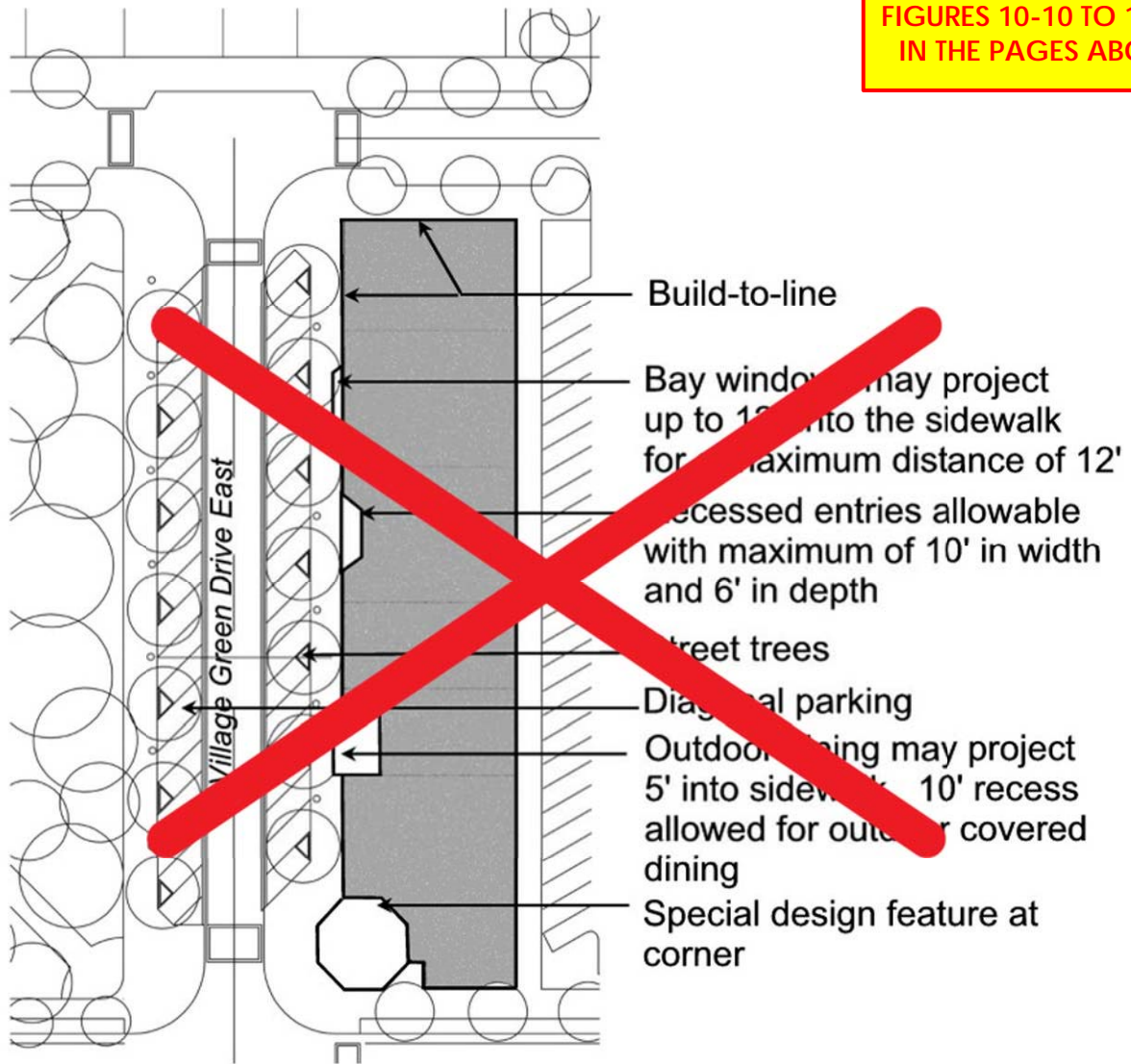
<b>CC/SA-WR Development &amp; Design Standards</b>	
<b>Height</b>	
<b>Design Intent:</b> <i>To create building walls and massing that define, but do not overwhelm, the public spaces.</i>	
Height Limit (Figure 10-13)	35-foot maximum; In no case shall the top of a building parapet or roof façade along the storefront be less than 25 feet.
Ground Floor (Figure 10-13)	Minimum 16 feet as measured from ground floor grade to second floor or roof to ensure quality retail space.
Exceptions	Towers, cupolas, steeples, dormers, spires, flagpoles, and similar architectural elements if the element is integrated into the overall architectural design and occurs at significant locations within the Village Center (eg. building corners) providing a landmark to reinforce the sense of place.
<b>Mid-Block Pedestrian Ways</b>	
<b>Design Intent:</b> <i>To link the off-street parking to the primary retail streetscape which provides the primary pedestrian circulation within the Village Center.</i>	
Location	One mid-block pedestrian way is required between off-street parking and the street (sidewalk) in each block. The pedestrian ways are encouraged to align on opposite blocks to facilitate a mid-block street crossing on the primary retail streets.
Width (Figure 10-14)	Pedestrian ways shall be a minimum of 15 feet and a maximum of 25 feet in width.
Treatment (Figure 10-14)	Paving, landscaping and illumination along pedestrian ways shall be consistent with the design and quality of the streetscape;  Retail entries, show windows and displays are encouraged along the facades aligning the pedestrian ways;  Porticos or trellises that project from the face of the buildings should be located along the street and within the parking area to announce the location of the pedestrian ways. The portico or trellis may project into the build-to-line (sidewalk) a maximum of 6 feet and into the parking area a maximum of 8 feet, while maintaining a minimum vertical clearance of 9 feet.
<b>Large Floor Plate Retail</b>	
<b>Design Intent:</b> <i>To break down the mass of large buildings so that they are generally consistent with the smaller Village Center retail buildings.</i>	
Building Façades: Articulation and Form (Figure 10-15)	Building facades should emulate the scale of the small Village Center retail by physically articulating walls and/or providing changes of materials with a varying module of 35 to 50 feet along the street. Changes in the roof or parapet height are encouraged when consistent with the articulation of the wall. Special architectural features, such as turrets, raised roof elements etc., should be at the entries to signify and highlight the entrances to the building. The building must meet the requirements of the build-to-line on the primary <sup>1</sup> and secondary <sup>2</sup> retail streets.
Building Façades: Window Placement and Rhythm (Figure 10-15)	Building facades shall have windows with glazing that permits visibility into the store along all facades facing a primary retail street <sup>1</sup> and along the primary building wall facing the store's major parking field. <ul style="list-style-type: none"> <li>■ Building facades facing primary retail streets<sup>1</sup> shall have windows with clear glazing above a 30-inch maximum high bulkhead for a minimum of 75% of the length of the wall.</li> <li>■ Building facades facing secondary streets<sup>2</sup> do not require windows if the wall is constructed of quality materials and is highly articulated with architectural detailing.</li> <li>■ Building facades facing the primary parking area shall have windows with clear glazing above a 30-inch maximum high bulkhead for a minimum of 50% of the length of the wall.</li> <li>■ Secondary facades facing the parking field do not require windows if the wall is constructed of quality materials and is highly articulated with architectural detailing.</li> </ul>

<b>CC/SA-WR Development &amp; Design Standards</b>	
Building Entries (Figure 10-15)	<p>A primary entry shall be located facing the primary retail street<sup>1</sup> with the doors located within 25 feet of the build-to-line (sidewalk). For the purposes of creating activity along the retail street frontage, the primary entry shall be functional and not treated as a “back door” to the business;</p> <p>A small pedestrian plaza (minimum 25’ X 25’) is encouraged to be located at the entry adjacent to the primary retail street;<sup>1</sup></p> <p>A secondary entrance may be allowed facing the main parking field.</p>
Service Areas (Figure 10-15)	<p>Truck dock and service areas shall be fully enclosed (including a roll up door) and of sufficient size to accommodate the largest service truck within the enclosed service area, mechanical equipment, trash and cardboard collection, etc.;</p> <p>Service areas shall be accessed from the secondary streets.<sup>2</sup> No service access is allowed from a primary retail street.<sup>1</sup></p>
Parking Access	<p>Access to parking areas from streets that have diagonal parking shall be limited. The City may approve an access point to the street between the large floor plate retail and adjacent in-line shop buildings.</p>
Shopping Carts	<p>A shopping cart management plan is required and shall be approved concurrently with the associated Design Review permit.</p>
<b>Parking</b>	
<b>Design Intent: To provide adequate parking while minimizing the visual impacts of off-street parking areas.</b>	
Off Street Parking (minimum and maximum)	<p>Retail/Office/Service—One (1) space per 300 square feet.</p> <p>Residential—One (1) space per unit.</p> <p>All other uses per City of Roseville Zoning Ordinance.</p>
On-Street Parking	<p>On-street parking shall be in addition to required off-street parking;</p> <p>Diagonal on-street parking will be privately owned and maintained. Such spaces shall be distinguished from the public street (right of way) by a colored paving mark.</p>
Off-Street Parking Access	<p>Vehicular access to off-street parking shall be from secondary streets and not from Village Green Drive, Village Green Drive East or Village Green Drive West. (See exception for Large Floor Plate Retail above.)</p>
Screening (Figure 10-16)	<p>The perimeter of off-street parking areas abutting a street shall have a minimum 6-foot wide landscape setback, with a 4-foot high concrete/masonry wall along the parking lot side of the setback.</p>
<b>Development Approval</b>	
Processing	<p>All CC/SA-WR large lot parcels shall be planned, processed and approved concurrently.</p>

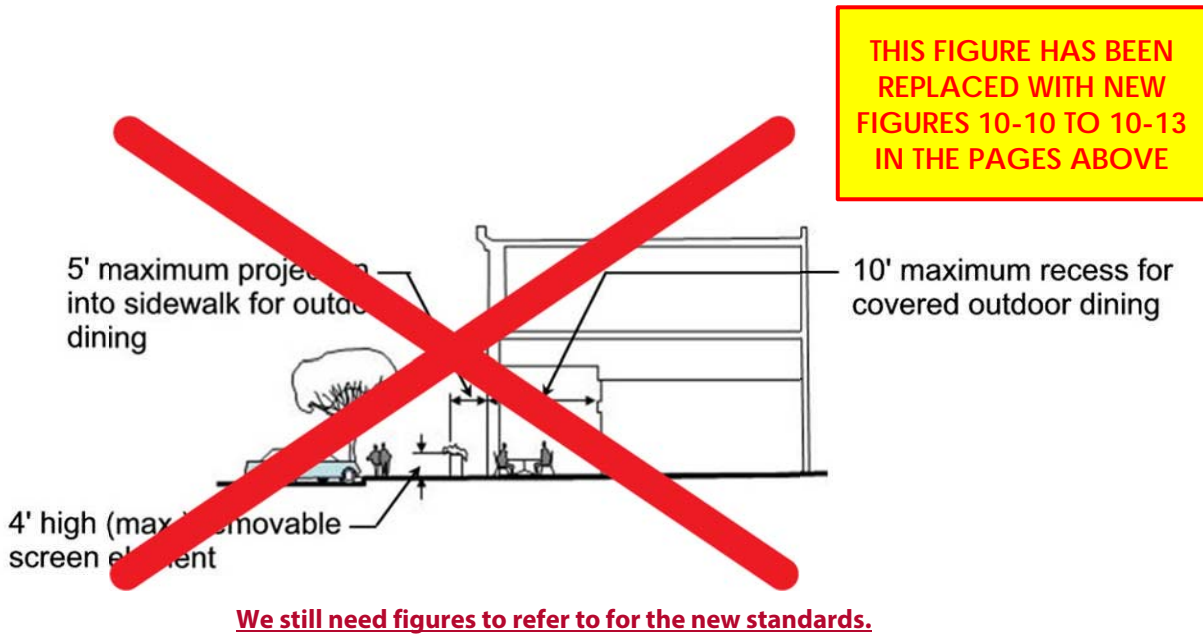
1. — Streets with retail on both sides or retail on one side and park on the opposite side.  
 2. — Streets with retail on one side and residential on the opposite side.

**Figure 10-10: Village Center CC Front Setbacks Recesses and Projections Plan View**

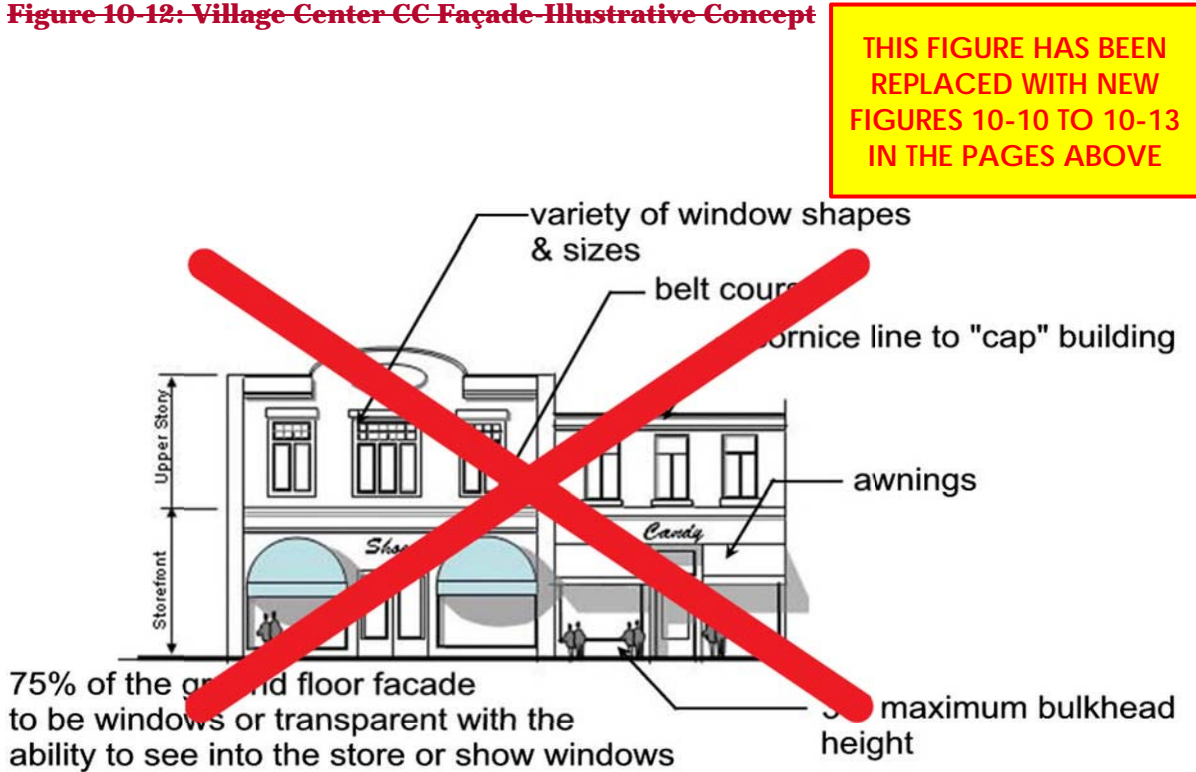
THIS FIGURE HAS BEEN REPLACED WITH NEW FIGURES 10-10 TO 10-13 IN THE PAGES ABOVE



**Figure 10-11 Village Center CC Front Recess and Projection Cross Section**

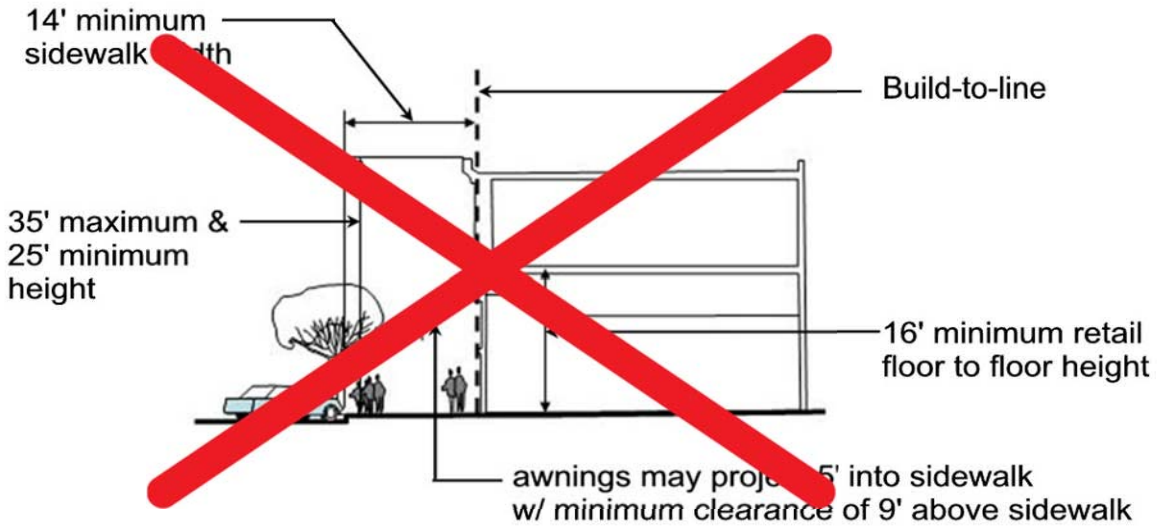


**Figure 10-12: Village Center CC Façade Illustrative Concept**



**Figure 10-13: Village Center CC Building Height Cross Section**

THIS FIGURE HAS BEEN REPLACED WITH NEW FIGURES 10-10 TO 10-13 IN THE PAGES ABOVE



**Figure 10-14: Mid-Block Pedestrian Way Plan View**

THIS FIGURE HAS BEEN REPLACED WITH NEW FIGURES 10-10 TO 10-13 IN THE PAGES ABOVE

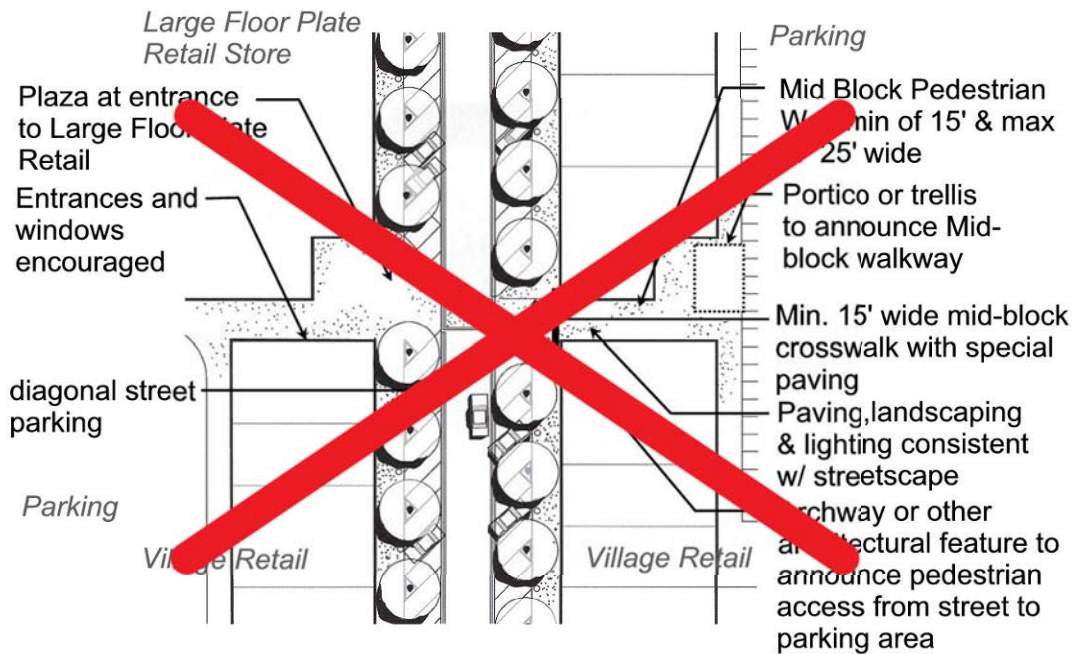


Figure 10-15: Village Center Large Floor Plate Retail Plan View

THIS FIGURE HAS BEEN REPLACED WITH NEW FIGURES 10-10 TO 10-13 IN THE PAGES ABOVE

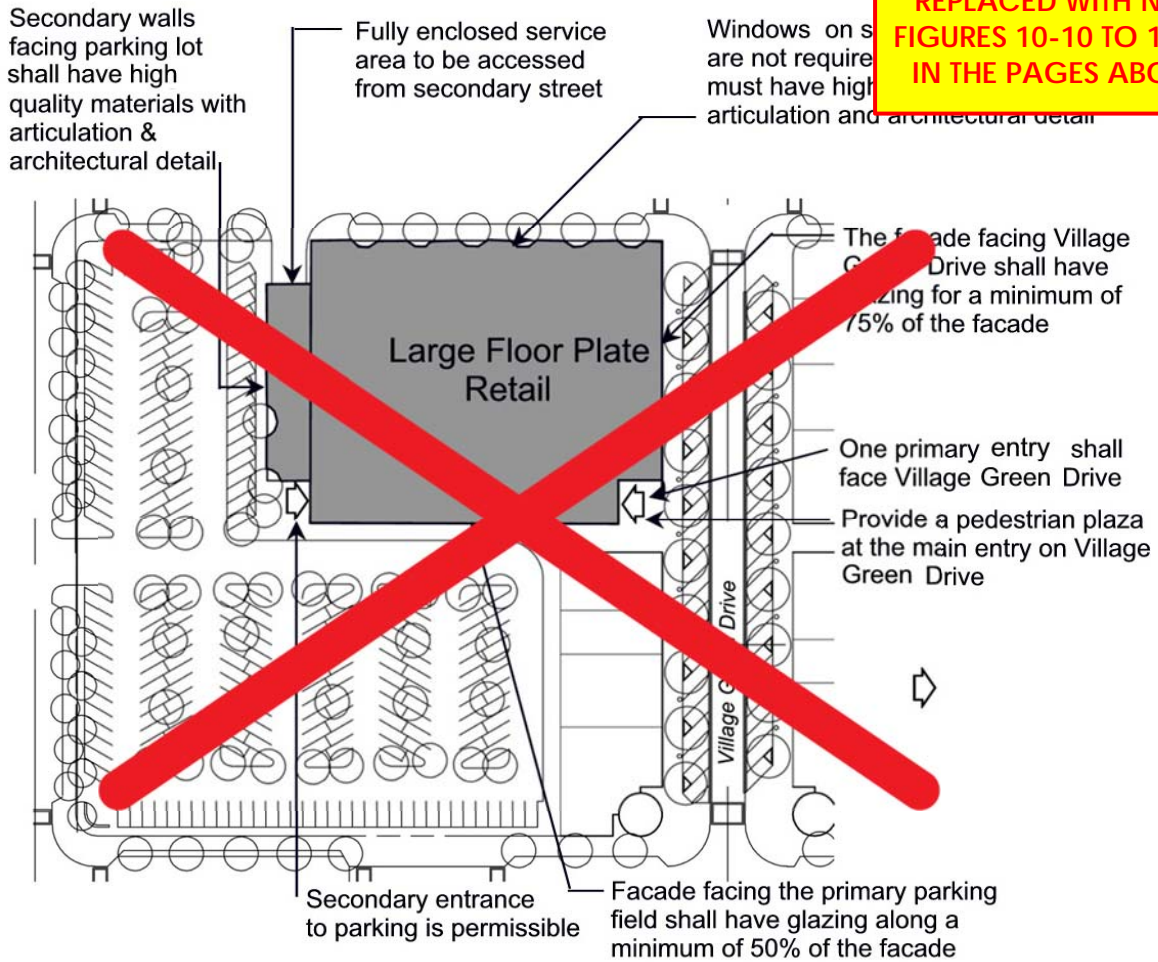
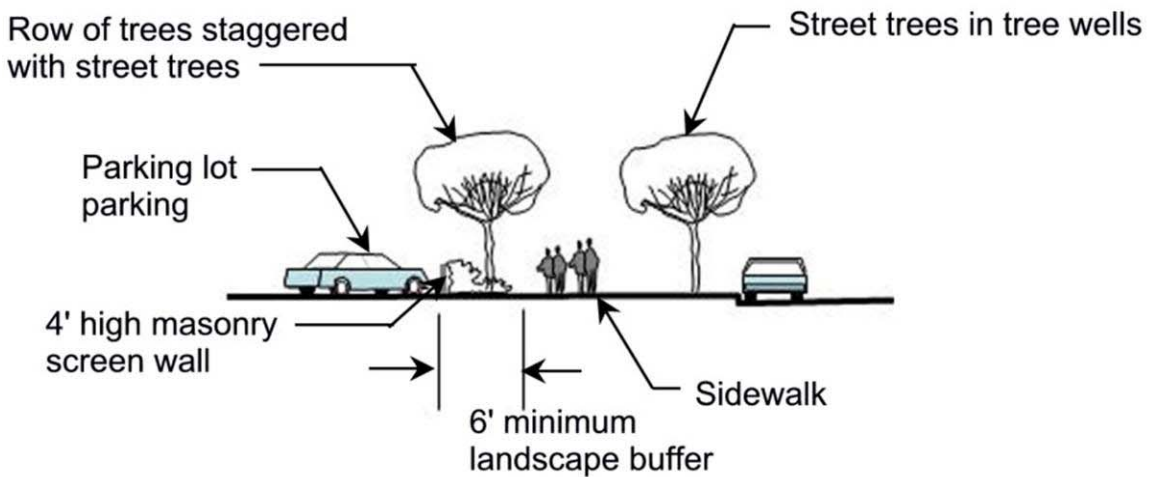


Figure 10-16: Village Center Parking Screening-Cross Section



□ PUBLIC & QUASI-PUBLIC SPACES



The Village Center provides public and quasi/public spaces for people to gather and to reinforce community identity. The centrally located Village Green, a ~~3.71-85~~-acre traditional urban park element, provides the visual focus of the Village Center. The Village Green is intended to accommodate passive recreation, provide a visual respite for residents, shoppers and employees, and form a community gathering place. It includes a central pavilion as a venue for a wide variety of

community activities, including concerts, fairs, exhibits, markets and other events that will bring the community to the Village Center. The form of the Village Center calls for the adjacent commercial uses to face onto the Village Green. A second park site, a City neighborhood park, is included on the south end of the Village Center. This ~~8.98-9.93~~-acre park is intended to meet the active recreational needs of residents within the Village Center and adjacent neighborhoods.

The Village Center incorporates a 10.83-acre Public/Quasi-Public site to be used for a church and private school. The church and private school create another identifying community element and activity center. The church site has been positioned to face the Village Green from across Pleasant Grove Boulevard, and is aligned with the axis of Village Green Drive creating a visual focal point. The Church is required to include a spire, tower or other architectural element to align with the visual centerline of Village Green Drive and provide a focal point for the Village Center.



## □ MINOR RESIDENTIAL DENSITY ADJUSTMENTS

Minor Residential Density Adjustments are permitted within the Village Center subject to the requirements of Section 4.3, with the following additions:

1. The Minor Density Adjustment may not result in a reduction of units within the Village Center; and
2. The Minor Density Adjustment may only be approved if determined by the Planning Director that it improves the ability to achieve the Planning Principles for the Village Center and produce the residential product types envisioned.

## 10.4 AFFORDABLE HOUSING PLAN

Consistent with the General Plan affordable housing goal, ten percent (10%) of the units in the WRSP have been designated for middle-, low- and very-low income households. The WRSP affordable housing goal has been allocated to specific residential parcels. This includes the allocation of 75 low-income rental and 75 very low-income rental units to Parcel W-25 in the Village Center. Affordable units shall be provided in accordance with Section 5 of the Specific Plan. Included is the requirement for a *Supplemental Affordable Housing Development Agreement* to detail specific requirements and obligations prior to the issuance of any building permits for Parcel W-25.

## 10.5 CIRCULATION PLAN

The Village Center is a district where preference is given to the pedestrian rather than the automobile. The mix, proximity, and intensity of uses, along with the underlying grid street pattern, encourage alternative forms of transportation including walking, bicycling and transit. All uses are in easy walking distance, within 1,500 feet of the Village Green and a central transit stop. Numerous design elements, including wide sidewalks, enhanced pedestrian crossings, ~~mid block pedestrian ways~~, dense tree canopies, street furnishings, pedestrian scale lighting, signage and front forward building designs are intended to promote a comfortable and inviting pedestrian environment.

In accordance with the City's General Plan, the Village Center is designated as a Pedestrian District. The intent of the Pedestrian District is to place a greater emphasis on the pedestrian rather than the automobile by implementing measures to improve walkability through enhanced safety, security and convenience within and through the District. The Village Center incorporates numerous elements, from its basic form to unique pedestrian and vehicular circulation standards, which promote walkability and support the intent of the Pedestrian District. In designating the Village Center as a Pedestrian District, the City acknowledges that certain design features may slow the speed of vehicle travel and may reduce the vehicle level of service. The Pedestrian District overlay has been applied to the entire Village Center area.

## □ ROADWAYS

The Village Center incorporates a traditional grid circulation pattern providing multiple routes and options for both pedestrians and automobiles. The conventional suburban emphasis on a hierarchy or functional classification of roadways is replaced by a general uniformity of street options. All roadways place equal emphasis on vehicular and pedestrian transportation. The unique nature of the Village Center roadway system necessitates variations to typical City street standards including on-street diagonal parking, wider sidewalks abutting commercial frontages, and sidewalk “bulb-outs” at intersections.

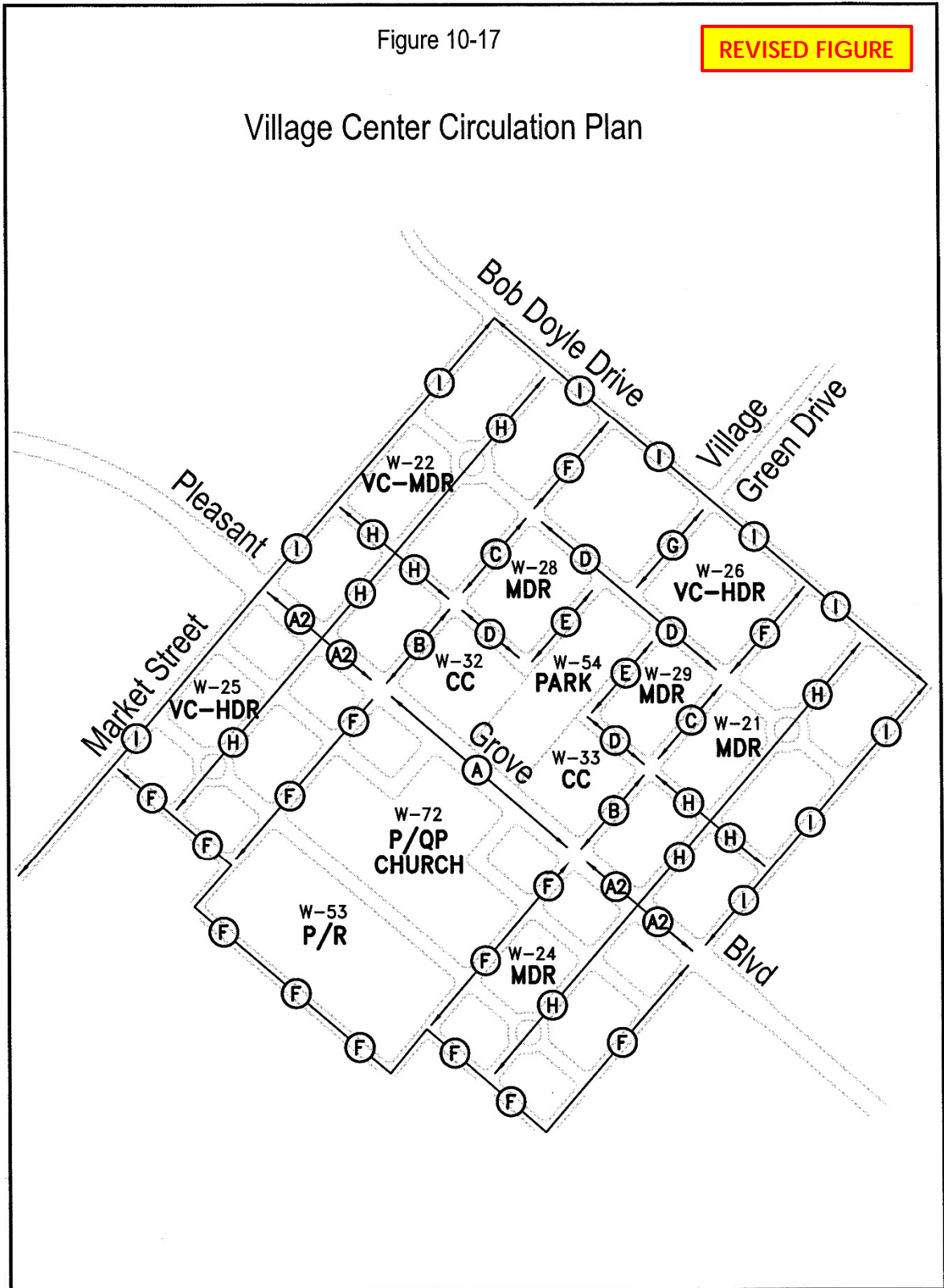
The Village Center’s grid roadway system shall include:

- Short blocks of 300-feet in length or less;
- Straight streets; and
- Intersections at regular intervals.

Roads will be in compliance with emergency vehicle access requirements. Internal streets included within projects on Village Center large lot parcels are required to complement the overall grid network. In addition, coordination is required to ensure that roadways and pedestrian access points in adjacent development connect to Village Center roadways and sidewalks.

The Village Center Circulation Plan is reflected on Figure 10-17, with lane capacity, right-of-way, sidewalk widths, parking and general landscape treatments summarized on Table 10-9. All roadways within the Village Center are required to be in conformance with Figure 10-17 and Table 10-9. Specific roadway sections for Village Center roadways are included as Figures 10-18 through 10-22. Landscape treatments, street light details and other streetscape elements are included in the WRSP Design Guidelines (Section 12).

Figure 10-17: Village Center Circulation Plan



Note: Underlying parcel basemap used in this figure are not regularly updated.

Refer to Table 4-1 for the most up to date unit and acre information.

**Table 10-9: Village Center Roadway Summary**

Street	Lanes	Right-of-Way	Sidewalk Width	On-Street Parking	Landscape Treatment	Landscape Median	Figure
<b>ARTERIAL ROADWAY</b>							
Pleasant Grove Blvd. (A) (Adjacent to Commercial & Park)	4	92'	6'- <del>8'</del> <sup>12'</sup> <sup>1</sup>	None	6' Planter Strip	30'	10-18
Pleasant Grove Blvd. (A2) (Residential on both sides)	4	92'	6'	None	6' Planter Strip	30'	10-18
<b>COMMERCIAL ROADWAYS</b>							
<del>Village Green Drive (B)</del>	<del>2</del>	<del>27'</del>	<del>14'</del>	<del>Diagonal</del>	<del>Tree Planters</del>	<del>-</del>	<del>10-19</del>
<del>Village Green Drive East/West (B2)</del>	<del>2</del>	<del>27'</del>	<del>12'-14'</del> <sup>2</sup>	<del>Diagonal</del>	<del>Tree Planters</del>	<del>-</del>	<del>10-19</del>
<del>East/West at Village Green (C)</del>	<del>2</del>	<del>38'</del>	<del>12'-14'</del> <sup>2</sup>	<del>Parallel</del>	<del>Tree Wells</del>	<del>-</del>	<del>10-20</del>
<del>North/South at Commercial (B)</del>	<del>2</del>	<del>60'</del>	<del>5'-6'</del>	<del>Parallel</del>	<del>5'-6' Planter Strip</del>	<del>-</del>	<del>10-20</del>
<del>East/West at Commercial (D)</del>	<del>2</del>	<del>61'<sup>38'</sup></del>	<del>5'-6'<sup>14'</sup></del>	<del>Parallel</del>	<del>6' Planter Strip</del>	<del>-</del>	<del>10-20</del>
<del>Commercial/Residential Street (E)</del>	<del>2</del>	<del>38'</del>	<del>6'-12'</del> <sup>3</sup>	<del>Parallel</del>	<del>Tree Wells</del>	<del>-</del>	<del>10-22</del>
<del>Collector at Perimeter (I)</del>	<del>2</del>	<del>42'</del>	<del>5'</del>	<del>Parallel</del>	<del>Tree Wells &amp; 6' Planter Strip<sup>4</sup></del>	<del>-</del>	<del>10-22</del>
<del>Collector at Perimeter (I)</del>	2	42'	5'	Parallel	5' Planter Strip	-	10-22
<b>RESIDENTIAL ROADWAYS</b>							
<del>North/South Residential (C)</del>	<del>2</del>	<del>59'</del>	<del>5'-6'</del>	<del>Parallel</del>	<del>5'-6' Planter Strip</del>	<del>-</del>	<del>10-21</del>
<del>Residential at Park (E)</del>	<del>2</del>	<del>49'</del>	<del>5'</del>	<del>Parallel</del>	<del>6' Planter Strip</del>	<del>-</del>	<del>10-21</del>
Major Residential Street (F)	2	58'	5'	Parallel	5' Planter Strip	-	10-21
Residential Entry Street (G)	2	62'	6'	Parallel	6' Planter Strip	-	10-21
Minor Residential Street (H)	2	54'	5'	Parallel	5' Planter Strip	-	10-22
Alley (public)	1	20'	-	-	-	-	-

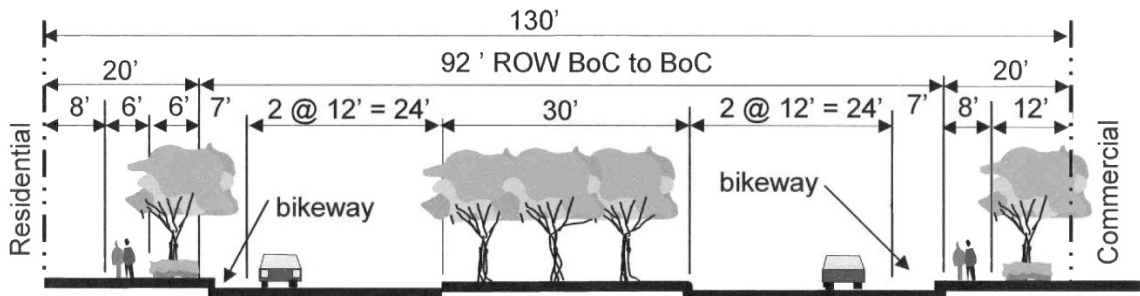
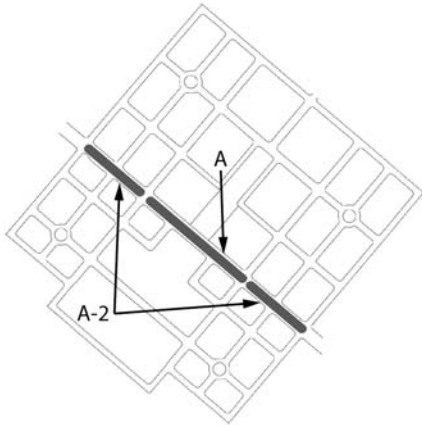
1. ~~128~~-foot sidewalk required adjacent to commercial and park; 6-foot sidewalk required adjacent to ~~residential~~ and public/quasi-public.
2. ~~14~~-foot sidewalk required adjacent to commercial; 12-foot wide sidewalk adjacent to park.
3. ~~12~~-foot sidewalk required adjacent to commercial; 6-foot sidewalk required adjacent to residential.
4. ~~Tree wells~~ adjacent to commercial; 6-foot planter strip adjacent to residential.

**Note: See WRSP Design Guidelines, for landscape requirements and other details.**



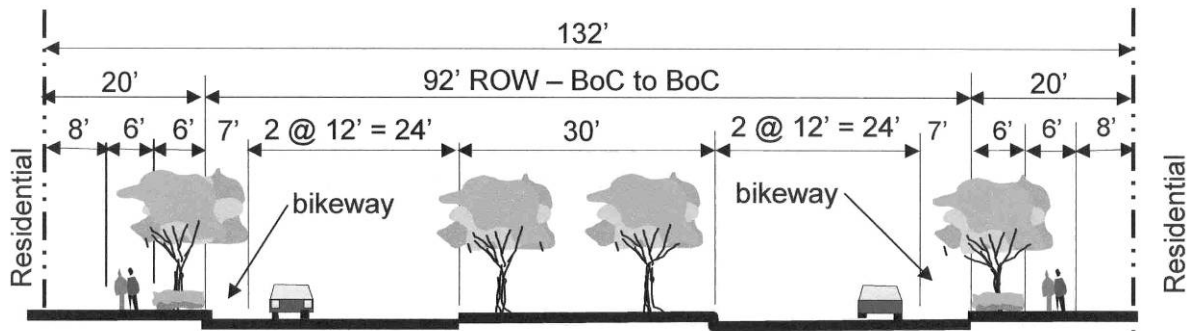
Typical Commercial Roadway

Figure 10-18: Village Center Pleasant Grove Boulevard Street Sections



Section A  
Pleasant Grove Blvd. @ Commercial

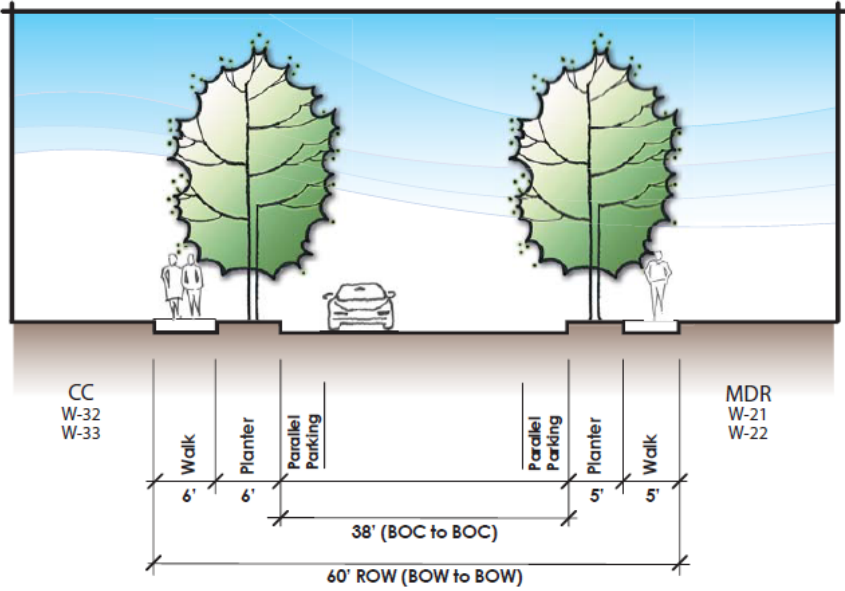
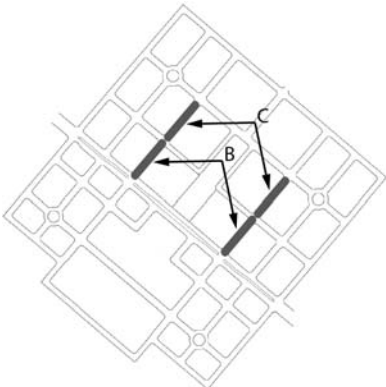
REVISED FIGURE



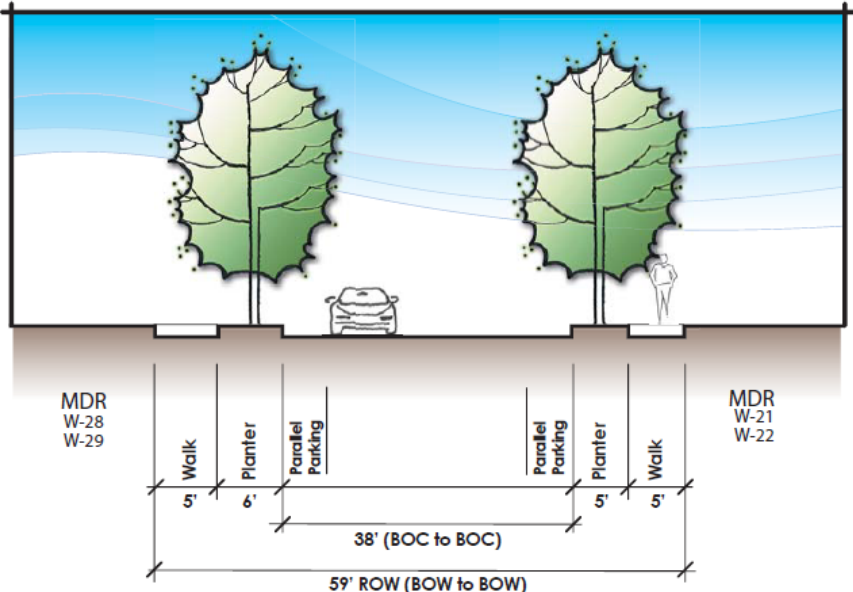
Section A-2  
Pleasant Grove Blvd. @ Residential

Figure 10-19: Village Center Drive & Village Plaza Drive Street Sections

NEW FIGURE



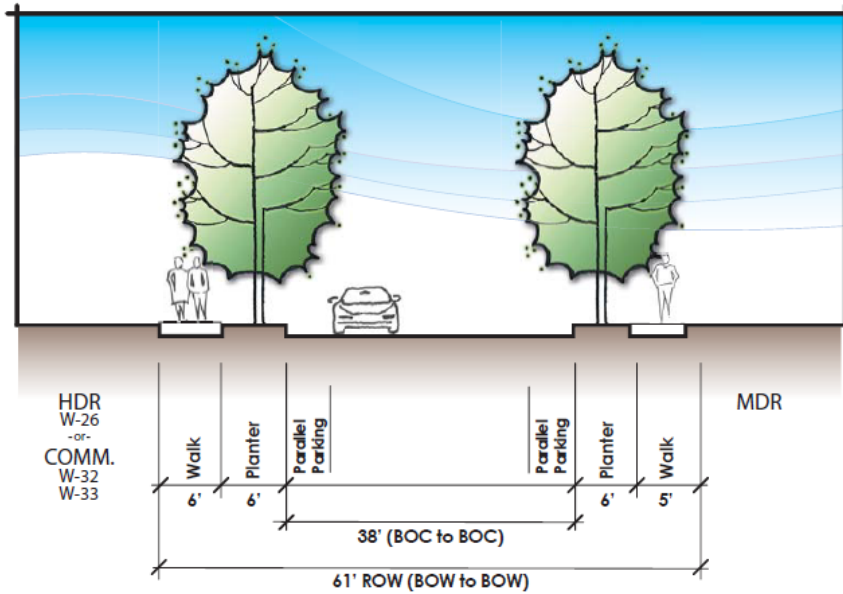
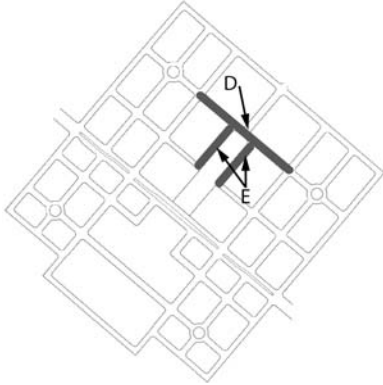
Section B: Village Center Drive and Village Plaza Drive at Commercial/MDR



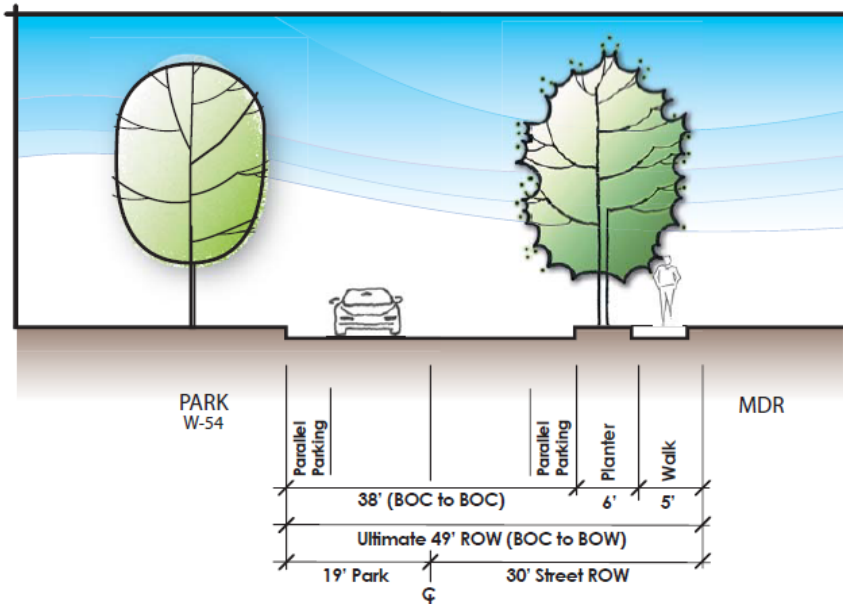
Section C: Village Center Drive and Village Plaza Drive at Residential

Figure 10-20: Park Interface Street Sections at Mayhill Drive & MDR

NEW FIGURE



Section D: Mayhill Drive



Section E: Village Green and Residential Interface

Figure 10-19: Village Center Village Green Drive Street Sections

FIGURE REPLACED

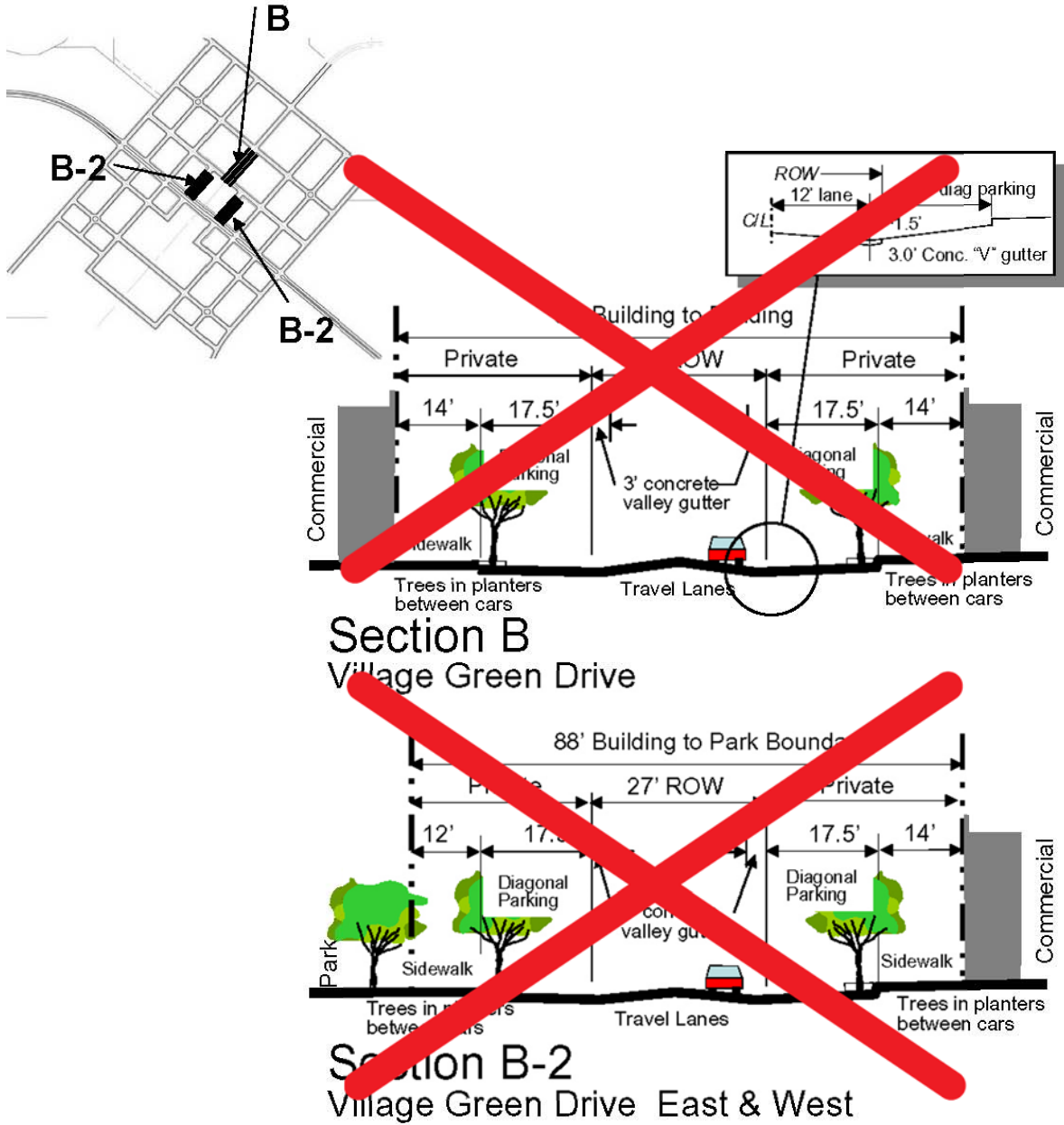
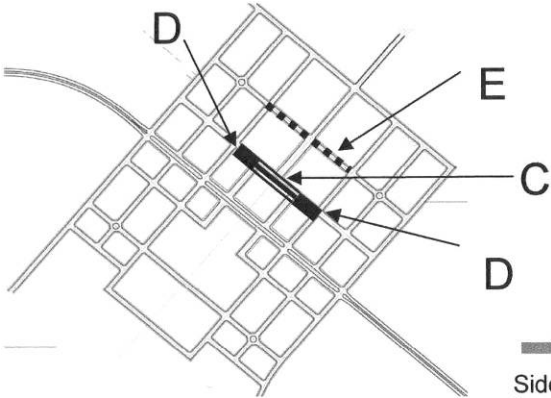
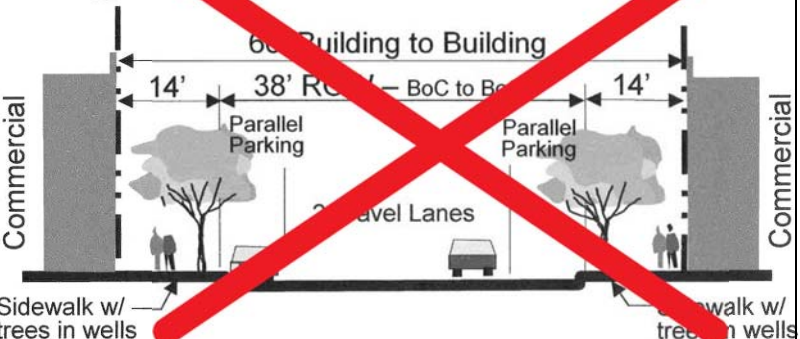


Figure 10-20: Village Center Commercial Street Sections

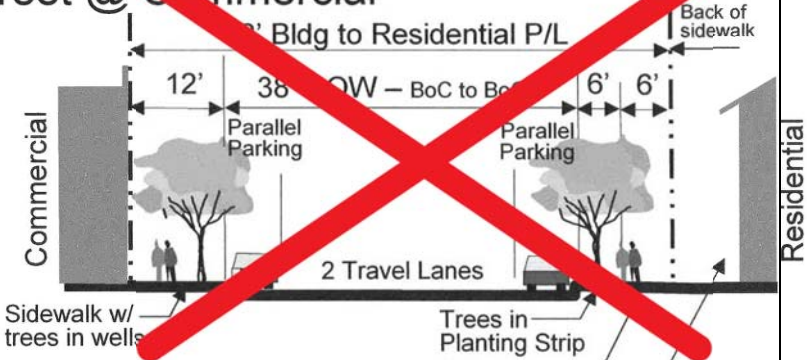
FIGURE REPLACED



Section C  
East/West Street @ Village Green



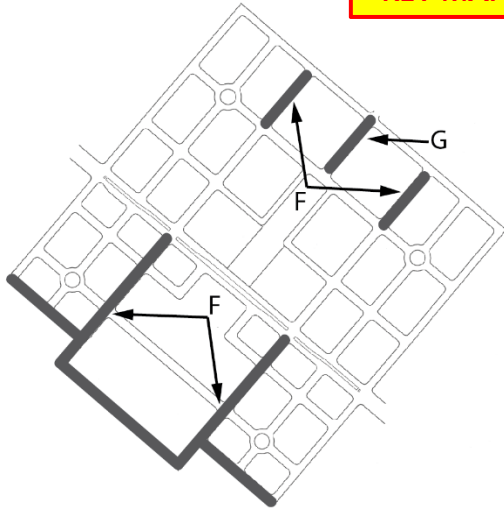
Section D  
East/West Street @ Commercial



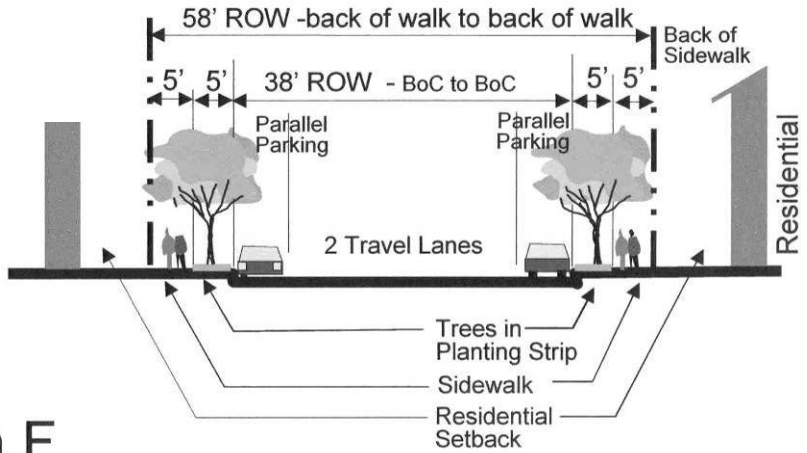
Section E  
East/West Street @ Commercial/Residential

Figure 10-21: Village Center Master Residential and Entry Residential Street Sections

KEY MAP UPDATED



Section F  
Major Residential Street



Section G  
Residential Entry Street

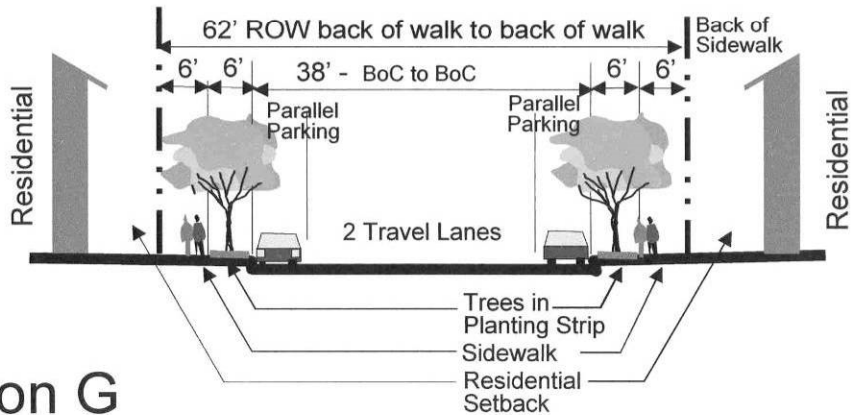


Figure 10-23 Village Center Gateway and Enhanced Pedestrian Crossing Illustrative

FIGURE REMOVED



Figure 10-24: Village Center Gateway and Enhanced Pedestrian Crossing-Plan View

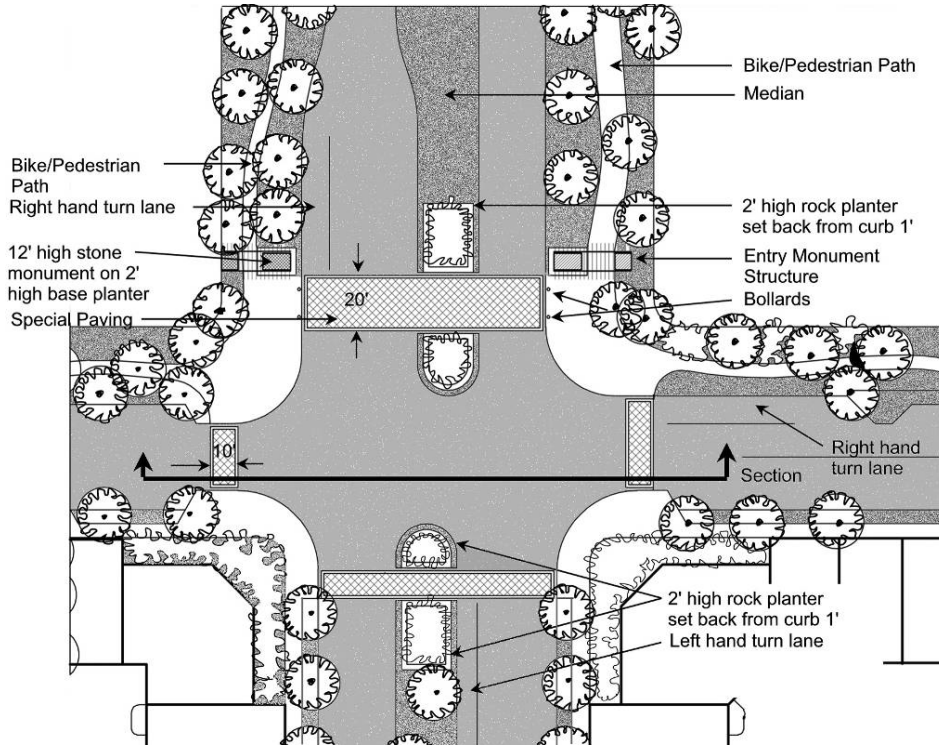
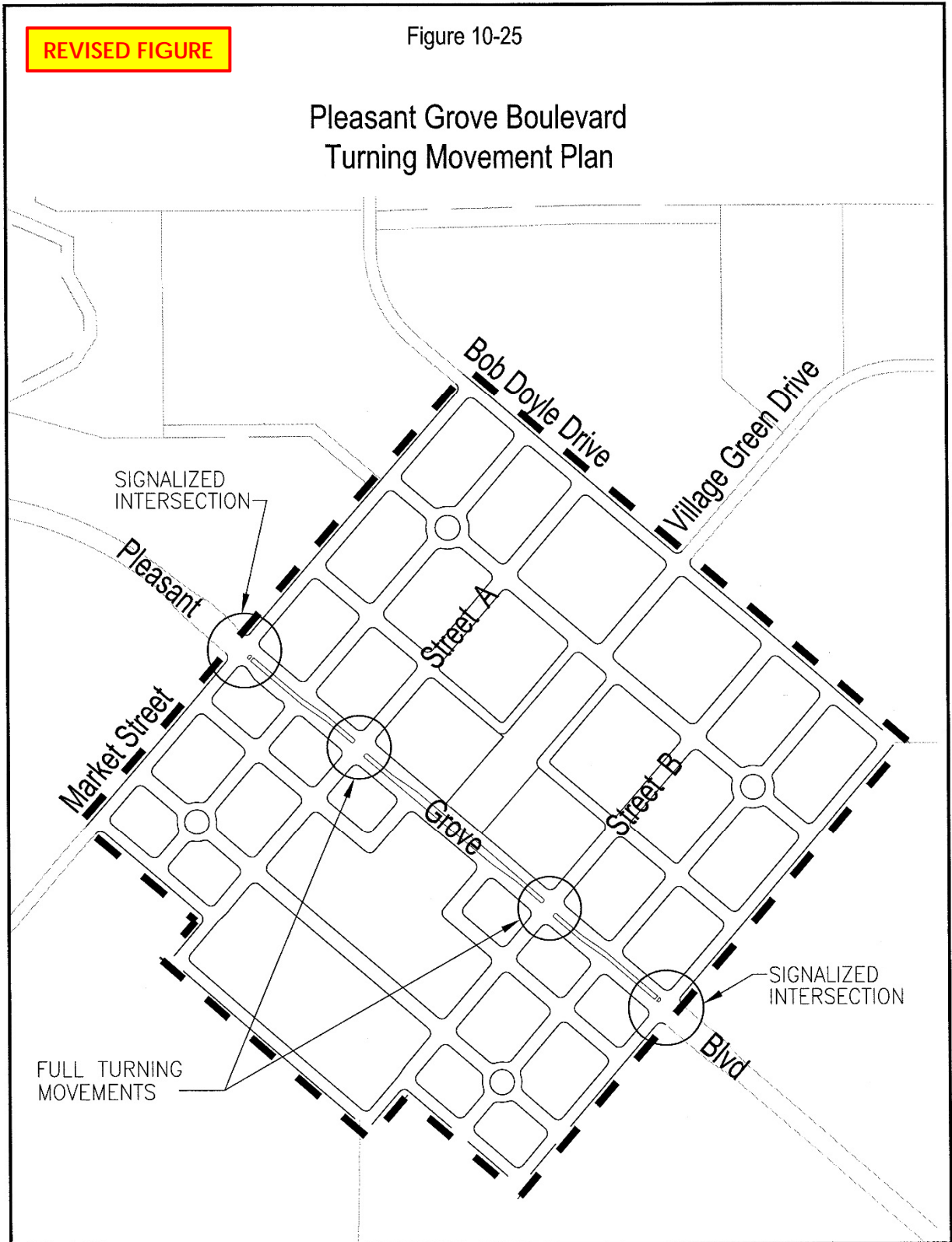


Figure 10-25: Pleasant Grove Boulevard Turning Movement Plan



**Commercial Roadways** (Figures 10-19 and 10-20), specifically Village Green Drive, Village Green Drive East and Village Green Drive West Pleasant Grove Boulevard, Village Center Drive, and Village Plaza Drive are the focus of commercial and social activity within the Village Center. These ~~2-lane~~ streets include wide sidewalks, significant tree plantings and other elements to enhance the pedestrian environment. ~~Adjacent~~ ~~Commercial~~ development is oriented towards ~~the~~



~~surrounding streets~~ and ~~wide sidewalks~~ ~~are provided to give pedestrians options to move between the commercial parcels and the central Village Green.~~ ~~with restaurant seating and activities permitted to spill out into the public spaces.~~ ~~In addition, Village Green Drive and its east and west extensions include diagonal on-street parking.~~ ~~As a result of off-street parking areas being placed to the rear of commercial uses, curb cuts along Village Green Drive and its extensions are limited to minimize conflicts with pedestrian traffic and allow on-street parking to be optimized to supplement required off-street parking.~~

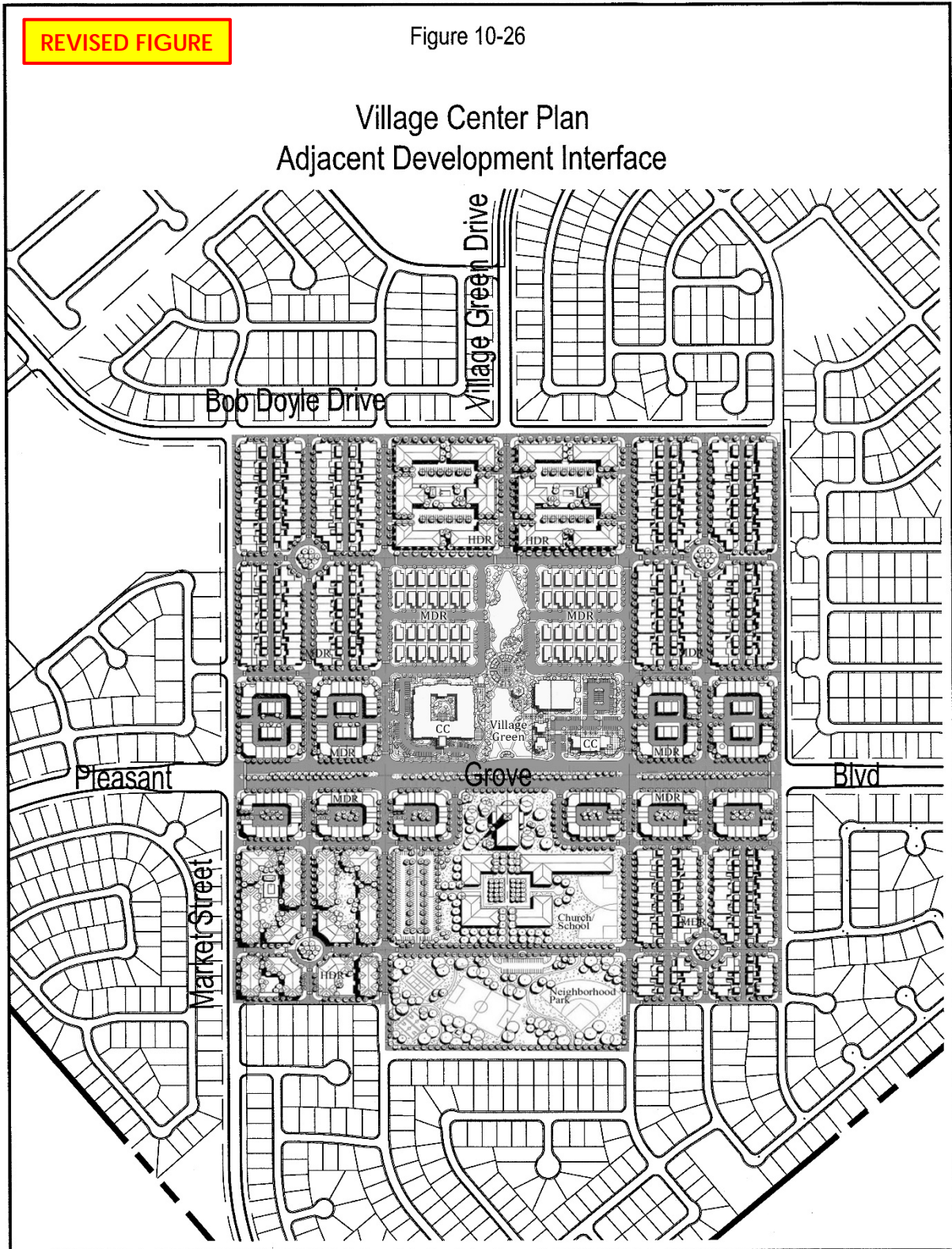
**Residential Roadways** (Figures 10-21 and 10-22) are 2-lane streets that provide access to Village Center housing. Residential streets include 5-foot to 6-foot wide planter strips between the curb and sidewalk for tree plantings and other landscaping. Housing faces onto the streets and is encouraged to include entries, porches and other features promoting activity. Alley access may be provided to Medium Density Residential (MDR) small-lot parcels to allow for rear loaded garages and services. Direct auto access from street to garage is prohibited along key Village Center roadways to minimize disruption to on-street parking opportunities (see Figure 10-6).

Four small privately maintained circular greens or roundabouts are located within the intersections of residential streets in the four quadrants of the Village Center (see Figure 10-17 for locations). The circular greens are landscaped elements that interrupt the visual linearity of the roadway system, provide points of orientation, and add to the green landscape quality of the Village Center. Each circular green will be landscaped to assist in orienting pedestrians and motorists within the Village



Center. Circular greens are part of the landscaped right-of-way.

Figure 10-26: Village Center/Adjacent Development Interface



## □ PARKS & RECREATION

Distinct to the Village Center are two City park sites, the Village Green and a traditional neighborhood park. Totalling approximately ~~12.69~~ ~~13.78~~ acres (~~net~~), the park facilities provide for both social and recreational opportunities and help define the character of the Village Center.

**Village Green** (Parcel W-54) is a unique ~~3.71~~ ~~3.85~~-acre (~~net~~) urban ~~square-park~~ forming the visual focus of the Village Center. The Village Green consists of grass with a symmetrical set of centrally oriented walkways. In the center is ~~a pavilion that functions as a venue for musical concerts and an activated gathering space that can be a venue for~~ community events. Large trees are located along the perimeter to provide shade and define the central community space. The Village Green is designated to provide passive recreation and as a gathering place for the community. Besides its passive recreation value and visual presence, the Village Green is designed to accommodate a variety of community activities such as a farmer's market, arts and crafts shows, celebrations, and performance arts that will attract the community to the Village Center. The Village Green will be owned and operated by the City of Roseville. The park preserves the north/south visual corridor which connects the church and neighborhood park site (W-53). A conceptual plan for the Village Green is included as Figure 10-27.

**Neighborhood Park** (Parcel W-53) is a ~~9.93~~ ~~8.98~~-acre (net) active recreation facility. The park will include soccer and baseball fields, hard courts, a playground, picnic area and parking lot. Facility planning for this park should also strongly consider adding a Community Garden to the park to serve the residential uses in the Village Center. The neighborhood park will serve the recreational needs of the Village Center and adjacent residential area. This facility will be dedicated to and maintained by the City of Roseville. A conceptual plan for the Village Center Neighborhood Park is included as Figure 10-28.:



Figure 10-27: Village Green Conceptual Plan

REVISED FIGURE

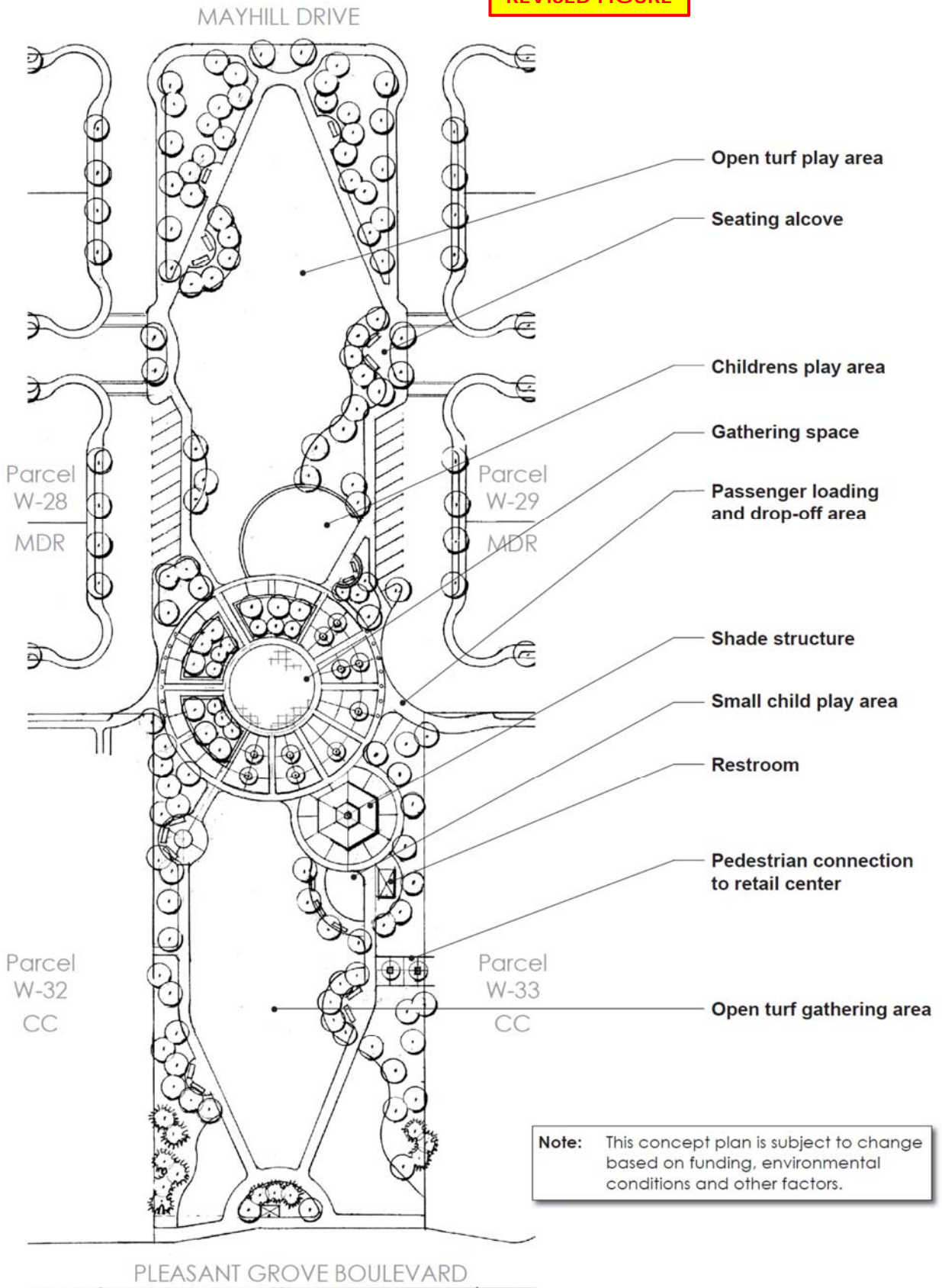
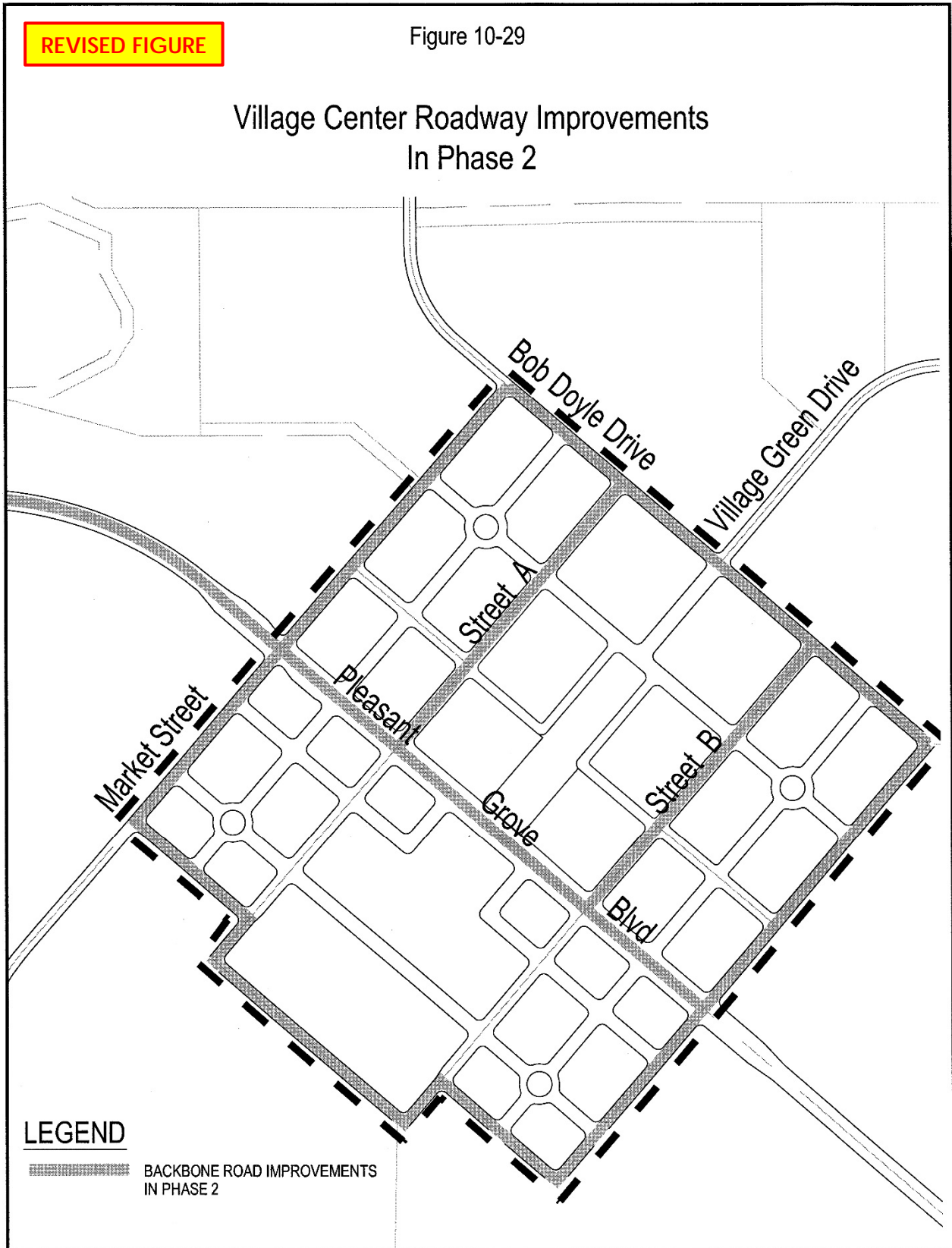


Figure 10-29: Village Center Roadway Improvements in WRSP Phase 2



**Materials**

Material selections shall utilize the plant palette contained herein. Signage shall be consistent with the materials listed below, subject to review and approval by the Parks and Recreation Department and subject to provisions in the Roseville Sign Ordinance.

- Backlit Raised Aluminum Letters
- Uplit Raised Aluminum Letters
- Flush Mount Channel Letters
- Flush Mount Masonry or Metal Wall Plaques
- Cast concrete signage
- Engraved stone

**Signage**

All sign elements on pilasters or walls shall use mounting hardware securely embedded into the surface onto which it is affixed. No epoxy-mounted elements are permitted. Where signs and monuments are to be uplit, such lighting equipment shall be approved by the City.

**12.2.2.4 VILLAGE CENTER GATEWAY ENTRANCE**



**Figure 12-25 Village Center Entrance Gateway Design Concept—Pleasant Grove Boulevard**

Along Pleasant Grove Boulevard, a significant entrance feature shall be incorporated into each edge of the Village Center district. The intent of these gateways is to visually define the Village Center as a unique district within the Plan Area, which is clearly distinguishable from other neighborhoods.

The gateway feature is an important element in creating an appropriate transition along the streetscape. Its design shall incorporate:

- Three-dimensional hardscape features such as monument, pilasters, trellises, raised planters, and/or other features that visually define the gateway along Pleasant Grove;
- Hardscape/landscape features shall not interfere with the City's site distance requirements;
- A change in street trees and landscape materials that are unique to the Village Center district;
- A change in street and accent lighting;

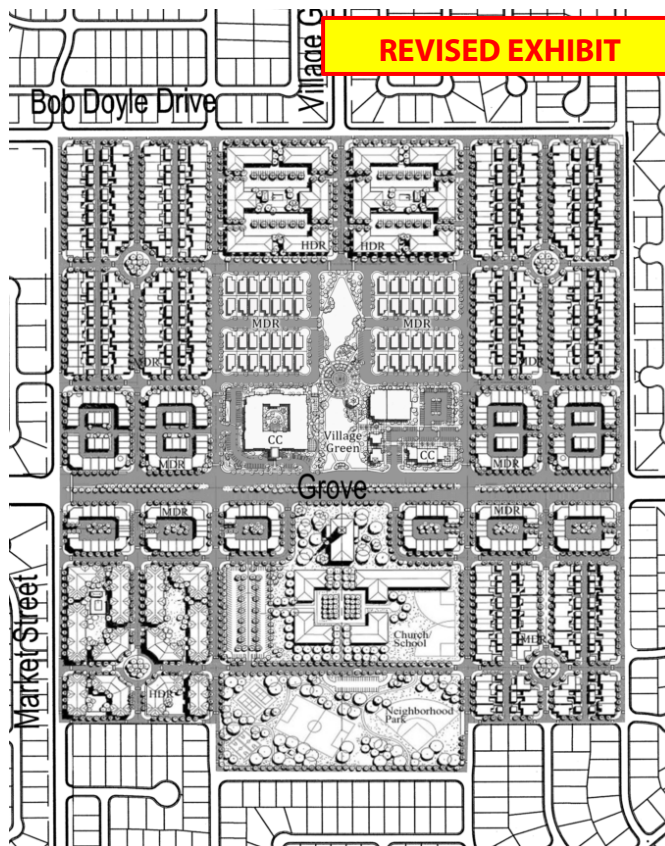
## 12.3.1 VILLAGE CENTER INTERFACE

### 12.3.1.1 INTENT OF EDGE INTERFACE

Critical to the Village Center's successful integration into the Plan Area is creating a proper interface between it and the surrounding residential neighborhoods. The Village Center is bounded mostly by low-density residential parcels, which are typically designed with internally-oriented streets, limited connection points to streets outside the subdivision, and walls around the perimeter of the subdivision. This type of development pattern will not be permitted adjacent to the Village Center.

The intent of this section is to ensure that the residential neighborhoods adjacent to the Village Center do not turn their back to the Village Center through the conventional subdivision design described above. Instead, the residential neighborhoods surrounding the Village Center should provide a clear, open connection to this district, such that each subdivision's internal streets become a natural extension of the Village Center's internal street network.

This interface will add continuity to the street network and create a desirable interface between the different housing product types in and out of the Village Center. This will also promote walkability between the Village Center and its adjacent neighborhoods.



### 12.3.1.2 RESIDENTIAL LOTTING ALONG VILLAGE CENTER EDGES

**Figure 12-38 Low Density Residential Lotting Interface with Village Center**

**Affected Parcels: W-1, W-2, W-7, W-8, W-10, W-11, & W-12**

To achieve a lotting interface along the Village Center edges, as outlined in the design intent above, residential lotting shall front onto the Village Center's perimeter streets to the extent feasible. Although this is a requirement of residential units within the Village Center, siting of low-density residential lots outside the Village Center must have careful design considerations to ensure that the desired interface is created. The lotting orientation differs on the north and south sides of Pleasant Grove Blvd., due to